

# Heat recovery ventilation unit with counterflow exchanger

## HRU-PremAIR



### Description

Heat recovery ventilation unit HRU-PremAIR is a modern device with 350 / 450 or 500 m<sup>3</sup>/h air flow @ 100 Pa. Unit is made from cutting edge materials - aluminium heat exchanger and EPP self-supporting casing. Depending on the model, following heat exchangers are used: counterflow aluminium heat exchanger (HRV) or counterflow enthalpy exchanger (ERV).

Enthalpy exchangers in HRU-PremAIR-E series have a polymer membrane that effectively recovers heat and moisture from the extract air. Such membrane works like a membrane in waterproof trekking clothing i.e. it allows water vapour to pass through, but not liquid water and air. The enthalpy exchanger also blocks the transfer of odours, bacteria and spores. The exchanger material, is needless to say, primarily optimized for maximum heat recovery efficiency.

PremAIR air handling units optionally can be equipped with the Constant Flow system, whose task is to maintain a constant air flow in the installation.

The device operation is controlled by an advanced PCB with wireless communication between control panels and sensors. In addition, the HRU-PremAIR can be connected to the Internet and controlled by a mobile application.

#### Available materials:

- HRU-PremAIR-350 - aluminium counterflow heat exchanger
- HRU-PremAIR-350E - counterflow enthalpy exchanger (heat and moisture recovery)
- HRU-PremAIR-450 - aluminium counterflow heat exchanger
- HRU-PremAIR-450E - counterflow enthalpy exchanger (heat and moisture recovery)
- HRU-PremAIR-500 - aluminium counterflow heat Exchanger
- HRU-PremAIR-...-CF - all model PremAIR can be equipped with the Constant Flow system

### Dimensions

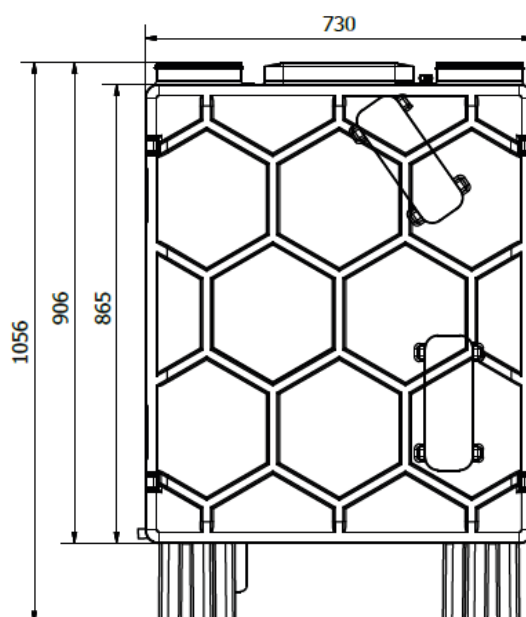
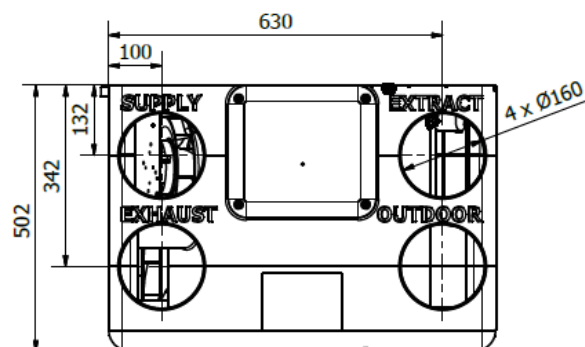

# Suspended heat recovery unit with a plate heat exchanger

## HRU-PremAIR

### Control

Ventilation units can be controlled in several ways:  
The **HRQ-SW3-I** rotary switch is an option for wired control of the ventilation unit and allows you to choose between 3 speeds (AWAY, HOME, HOME+)



4-button controller



**HRQ-BUT-LM11**



**HRQ-BUT-LM04**

This controller allows you to choose between 4 modes. The LM04 model has an AUTO button (instead of PARTY), recommended when there is at least 1 CO<sub>2</sub> or RH sensor in the system. Signalling of operation and errors by means of a LED diode.

Controller LCD, flush-mounted (**HRQ-BUT-LCD**)



This version has an LCD display, allows you to select 1 of 7 operating modes, program the calendar and read additional operating parameters such as temperatures, current fan speeds or the by-pass status.

It also allows you to configure ventilation speeds (according to user preferences).

Application for Android, iOS and via a browser (via the HRQ-GATE internet gateway)



**Application**



**HRQ-GATE**

The gateway is connected to the local network via the Ethernet port. Communication with the device is wireless. On-line control is possible after installing the application on Android and iOS or via a browser on a computer. The application graphically illustrates the operation of the device, allows you to change modes and read basic parameters.

Control via CO<sub>2</sub> and RH sensors (we recommend as additional control).



**HRQ-SENS-CO2**



**HRQ-SENS-RH**



**RQ-SENS-I-CO2**

(flush-mounted)

Each sensor also functions as a controller - it allows you to select from manual modes and, of course, engage AUTO mode. Indicates errors or dirty filters, but there is no filter status reset option.

Modbus gate (**HRQ-MODBUS**),



HRQ-MODBUS gate, which allows to control the device using the universal modbus protocol and RS485 data transmission.

Each sensor also acts as a controller - it allows you to select modes manually and, of course, triggering AUTO mode. Indicates errors or dirty filters, but there is no filter status reset option.



























#### NOTE!

Controller is not included in the kit. During purchase, choose the controller that is right for you. Multiple controllers can be connected at once - e.g. 4-button controller and an Internet gateway.

# Suspended heat recovery unit with a plate heat exchanger

## HRU-PremAIR

Control options table:

Model	Photo	Communication with unit	Power supply	No of modes	AUTO mode*	Display	Calendar	Dirty filter signalization	Changing speed settings
HRQ-SW3-I		cable 	230V 	3	no	no	no	no	no
HRQ-BUT-LM11		wireless 	battery 	4	no	no	no	yes	no
HRQ-BUT-LM04		wireless 	battery 	4	yes	no	no	yes	no
HRQ-BUT-LCD		wireless 	230 V 	7	yes	yes	yes	yes	yes
HRQ-GATE		wireless 	230 V 	6	yes	yes	no	yes	no
HRQ-SENS-CO2		wireless 	230 V 	5	yes	no	no	yes	no
HRQ-SENS-I-CO2		wireless 							
HRQ-SENS-RH		wireless 	battery 	4	yes	no	no	yes	no
HRQ-MODBUS		wireless 	n/d	7	yes	no	no	yes	no

\* requires at least 1 CO<sub>2</sub> or RH sensor

### Demand Control Ventilation, DCV

The AUTO mode is the most energy-efficient and demand driven mode of PremAIR units. Operation in the AUTO mode is possible when at least one carbon dioxide CO<sub>2</sub> or relative humidity RH sensor operates in the system.

In AUTO mode, the sensor (or several sensors) generates the so-called ventilation demand based on ambient air measurements. This request is sent wirelessly to the control board, which sets the efficiency of the fans in the range defined by AWAY and HOME(+ offset) speeds. It means, that in the case of factory settings, the range will be 15-70%.

**The RH sensor** will guard against excessive moisture. If there is a sudden increase in relative humidity (more than 3% within 24 seconds) or the reading exceeds 85%, the sensor will send 100% demand to the control panel to effectively and quickly reduce the RH level.

**The CO<sub>2</sub> sensor** will keep the carbon dioxide concentration below the specified level (the factory default is 800 ppm, you can choose between 700,800,900,1000 and 1100 ppm) thanks to the proportional PID algorithm.

This means that the request sent to the control board will change

gradually over time until the CO<sub>2</sub> concentration decreases. HRU-SENS-CO<sub>2</sub> sensors have 2 AUTO modes: Comfort and Eco. Comfort is the basic setting (i.e. 800 ppm by default), while Eco increases the limit by 250 (i.e. 1050 by default).

The CO<sub>2</sub> sensor is available in the following versions:

surface  
**HRQ-SENS-CO**



flush-mounted  
**HRQ-SENS-I-CO2**



In case of having several sensors, the unit control board will operate according to the highest indication (highest request). In the absence of any demand from the sensors, the ventilation unit will run at AWAY speed (lowest setting).

# Heat recovery ventilation unit with counterflow exchanger **HRU-PremAIR**

## Constant Flow (CF)

PremAIR air handling units optionally can be equipped with the Constant Flow system, whose task is to maintain a constant air flow in the installation. CF works by reading the difference between the dynamic pressure around the fan and the static pressure in the duct in front of the fan. The CF system constantly monitors the pressure in the ducts and if the resistance increases, it increases the speed of the fans to maintain a constant flow, such as on the first day when the ventilation unit was commissioned. During exploitation, the installation pressure is naturally disrupted (dirty filters, condensation of water in the heat exchanger, temperature difference changing the air mass). CF counteracts to those changes, thanks to which the airflows remain sustainable, and only a sustainable system takes full advantage of the air handling unit's capabilities.

## Performance

### Key performance features:

- Heat recovery:
  - HRU-PremAIR-350 - up to 90.3%
  - HRU-PremAIR-350-CF - up to 90.3%
  - HRU-PremAIR-350E - up to 91.2%
  - HRU-PremAIR-350E-CF - up to 91.2%
  - HRU-PremAIR-450 - up to 90.3%
  - HRU-PremAIR-450-CF - up to 90.3%
  - HRU-PremAIR-450E - up to 91.2%
  - HRU-PremAIR-450E-CF - up to 91.2%
  - HRU-PremAIR-500 - up to 82.6%
  - HRU-PremAIR-500-CF - up to 82.6%
- Entalphy exchangers with antimicrobial properties of the membrane, sesistant against mold and bacteria
- Hi-tech modern casing made of Expanded Polypropylene- EPP
- High mechanical resistance
- High thermal and acoustic insulation
- Modulated by-pass
- Constant Flow system
- Free-cooling functions – also referred as Passive Cooling (no energy is needed) or Night Cooling (mostly happens during night), can be used to cool a building with outdoor air, when the room temperature is higher than the outside temperature
- Free-heating functions - also referred as Passive Heating (no energy is needed), can be used to heat a building with outdoor air, when the room temperature is lower than the outside temperature
- Performance tested according to EN 13141-7 standard
- Complies with ErP2018
- Wall mounting racks and feet included
- Replaceable duct connections
- Wireless control through mobile application or web browser
- Remote control possible by any CO<sub>2</sub> or RH wireless sensor
- Light weight construction – only 32 kg!
- POLISH product

## Design

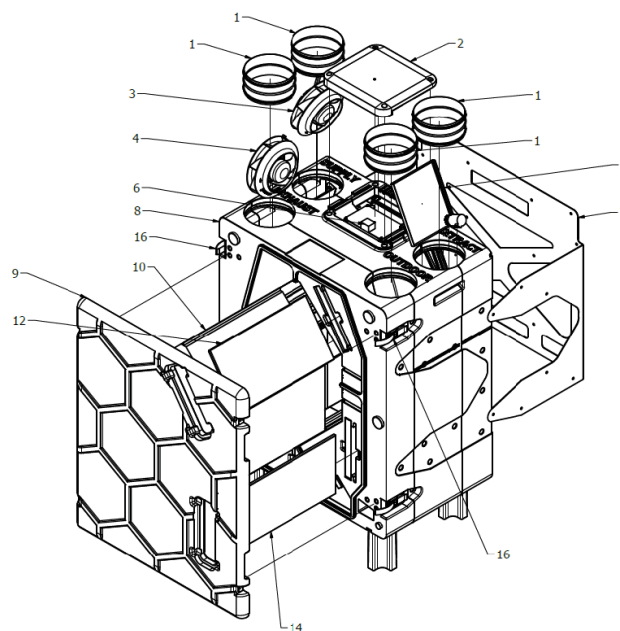

1. NSL connector (4pcs.)	9. Front cover
2. Control circuit cover	10. Heat exchanger
3. Supply fan	11. Extract filter cover
4. Extract fan	12. Extract filter G4
5. Bypass damper	13. Supply filter cover
6. Control circuit	14. Supply filter G4
7. Handling chassis	15. Mounting foot (4pcs.)
8. HRU casing	16. Clamp (4pcs.)

## Cooperation with the kitchen hood

The cooker hood can be connected to the MVHR system via the X25 contact on the main board of the SlimAIR heat recovery units. It is a potential-free contact. Short-circuits of contact inputs will result in an exhaust fan stopping completely during the period the contact is closed.

# Heat recovery ventilation unit with counterflow exchanger HRU-PremAIR

## Connecting the ground heat exchanger

Heat recovery unit has a possibility to connect the ground heat exchanger. This function allows you to control a valve that optionally supply air through the ground-to-air heating system. To do this, install a dedicated damper with the actuator (DATVTML).



Damper works by electric actuator DM-ML-06-230.



For quick mounting of the actuators we recommend specially designed stands DA-SUP-S and DA-SUP-M.

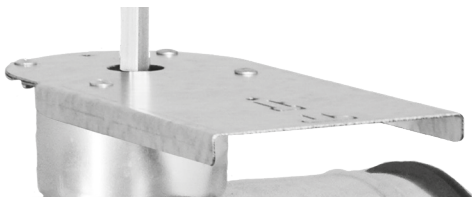

Actuators matching DA-SUP-S mountig plate	Actuators matching DA-SUP-M mountig plate
Alnor DM-ML-06	Alnor DM-ML-06
Belimo CM	Alnor DM-ML-08
Belimo LM	Belimo CM
Belimo TR	Belimo NM

## Connection

When you mount the actuator to the damper, you should remember to:

- the damper was open in the HRU-OUTDOOR direction (not GHE).
- the HRQ-SENS-500 external air temperature sensor should be routed and connected to the outdoor duct, placed before the air damper with the actuator. The temperature sensor should be connected to the X22 connector on the HRV control board.

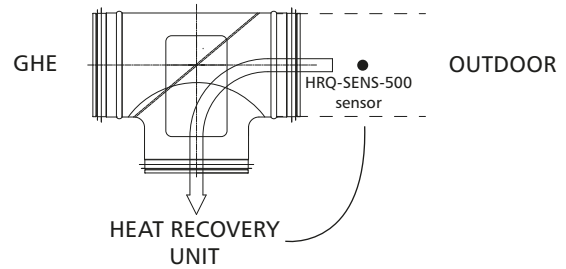

- if the actuator can be mounted in the left-right position, make sure it is mounted correctly as described below.

In order for the valve to operate correctly, the dumper with a DM-ML-06-230 electric actuator should be connected to X28 in the following order:

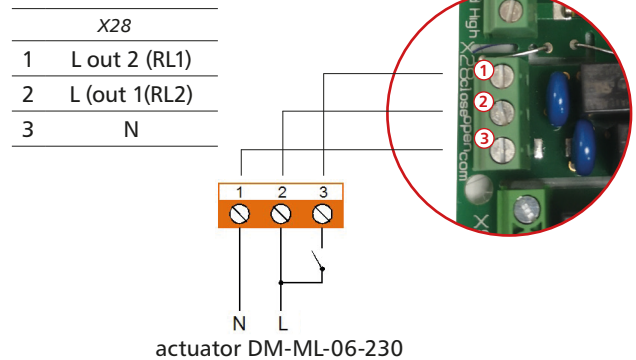

The automatics controls the valve based on the temperature at the outdoor. If the **Temperature outdoor** is lower than the **Geothermal Heat Exchanger Outdoor Temperature Below** or **higher than the Geothermal Heat Exchanger Outdoor Temperature Above** the valve will be opened and the air going to the unit will be taken from the ground heat exchanger. **Values Geothermal Heat Exchanger Outdoor Temperature Below** and **Geothermal Heat Exchanger Outdoor Temperature Above** are set in default mode for 5°C and 25°C. They can be edited from the service tool and the LCD Display controller.

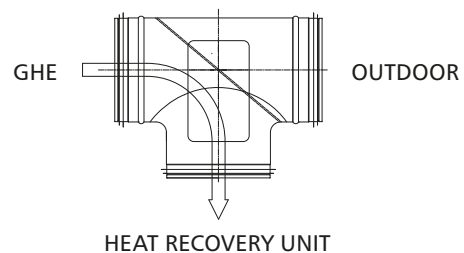

# Heat recovery ventilation unit with counterflow exchanger

## HRU-PremAIR

### Technical data

	HRU-PremAIR-350 / HRU-PremAIR-350-CF	HRU-PremAIR-350E / HRU-PremAIR-350E-CF	HRU-PremAIR-450 / HRU-PremAIR-450-CF	HRU-PremAIR-450E / HRU-PremAIR-450E-CF	HRU-PremAIR-500 / HRU-PremAIR-500-CF
Maximal efficiency % <sup>1</sup>	90,3	91,2	90,3	91,2	82,6
Efficiency % (acc. 1254/2014) <sup>2</sup>	85,5	84,7	85,2	82,1	81,5
Heat exchanger	counterflow, aluminium	counterflow, enthalpy	counterflow, aluminium	counterflow, enthalpy	counterflow, aluminium
Air flow [m <sup>3</sup> /h]	350 @ 100 Pa	350 @ 100 Pa	450 @ 100 Pa	450 @ 100 Pa	500 @ 100 Pa
Voltage [V/Hz]	230 / 50	230 / 50	230 / 50	230 / 50	230 / 50
Maximum power consumption [W]	150	150	220	270	220
Sound power level L <sub>WA</sub> [dB (A)]	49	49	51	51	49
Weight [kg]	35	35	35	35	35
Filters	ISO Coarse 70% (ISO ePM1 55% optional)	ISO Coarse 70% (ISO ePM1 55% optional)	ISO Coarse 70% (ISO ePM1 55% optional)	ISO Coarse 70% (ISO ePM1 55% optional)	ISO Coarse 70% (ISO ePM1 55% optional)

<sup>1</sup> Maximal thermal efficiency acc. to EN13141-7 at minimum air flow

<sup>2</sup> Thermal efficiency in reference point acc. to EN 13141-7, in compliance with UE 1254/2014

Performance curve HRU-PremAIR-350

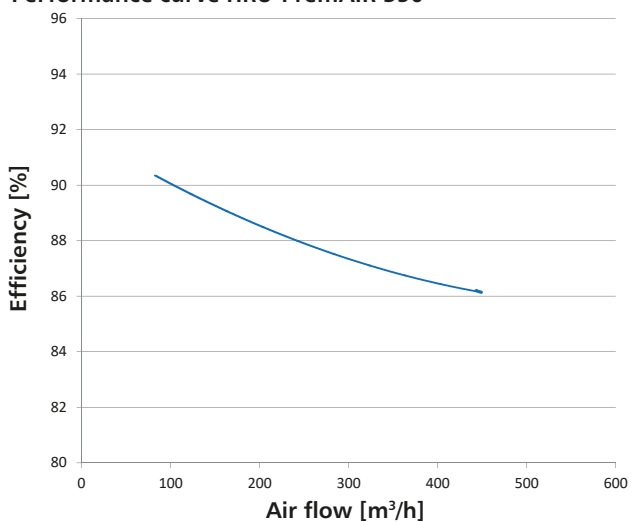

Performance curve HRU-PremAIR-450

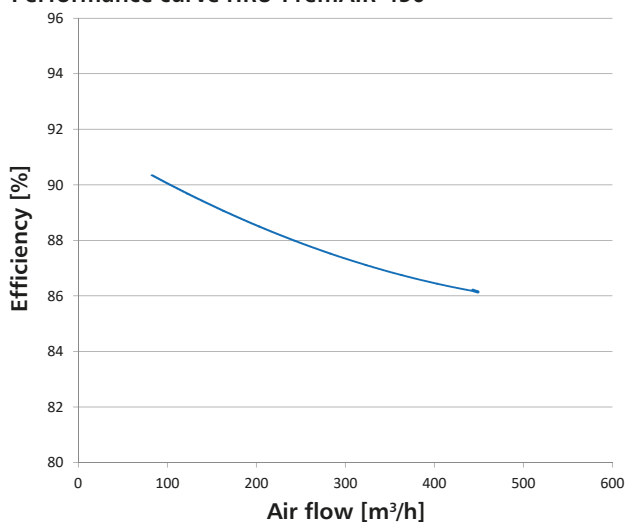

Performance curve HRU-PremAIR-500

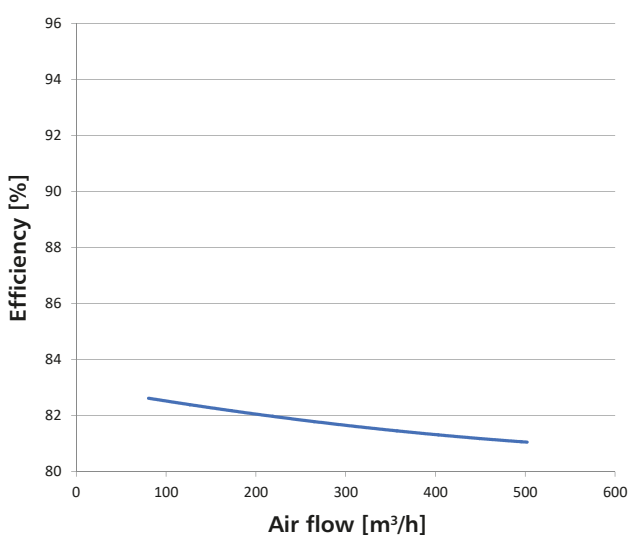

Performance curve - Heat (—) and moisture (—) recovery HRU-PremAIR-350E / HRU-PremAIR-450E

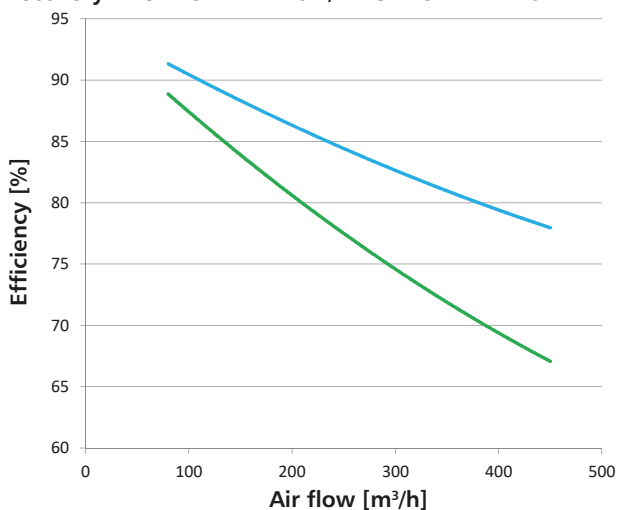

# Heat recovery ventilation unit with counterflow exchanger HRU-PremAIR

Air flow HRU-PremAir-350 / HRU-PremAir-350E

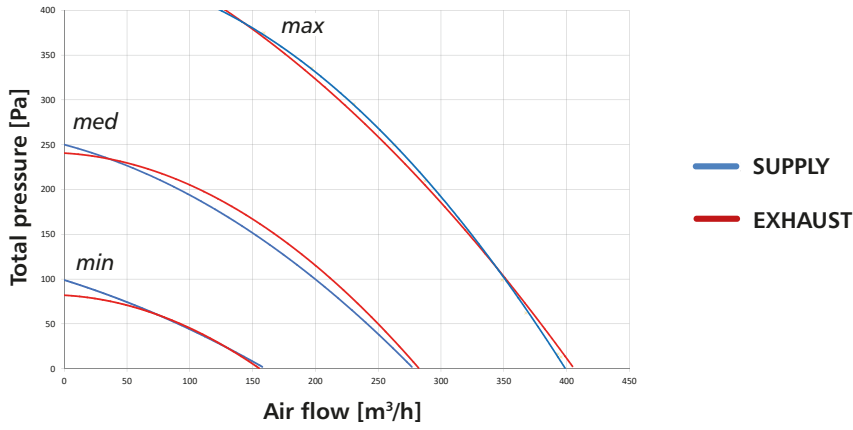

Air flow HRU-PremAir-450 / HRU-PremAir-450E

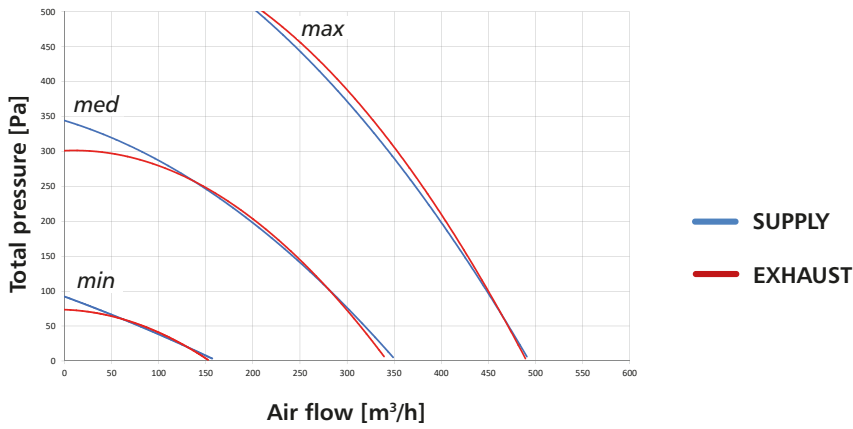

Air flow HRU-PremAir-500

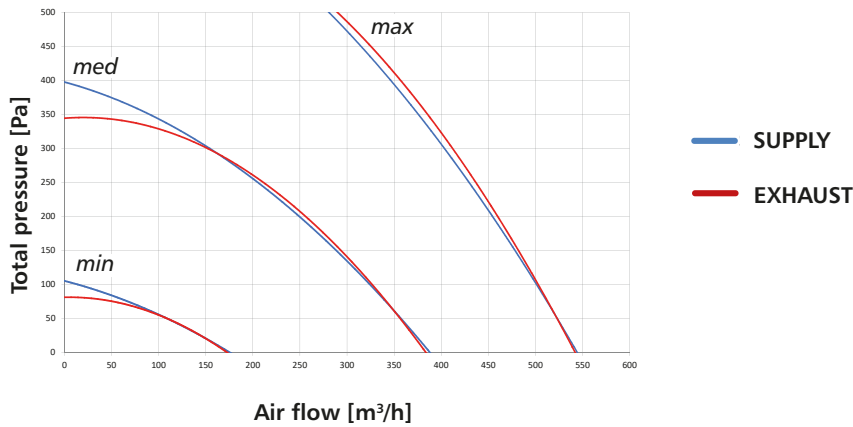

# HRU-PremAIR

## Filters

### Filter HRQ-PremAIR-FILT-G4 (standard)



G4 pleated panel filters create a larger media surface area for air filtration and ensure lower pressure drops. Filters are classified as in the ISO Coarse 70% according to ISO 16890 standards.

Code	Filter class	Dimensions [mm]
HRQ-PremAIR-FILT-G4	ISO Coarse 70 % (old G4)	423x223x23

### Filter HRQ-PremAIR-FILT-F7 (optional)

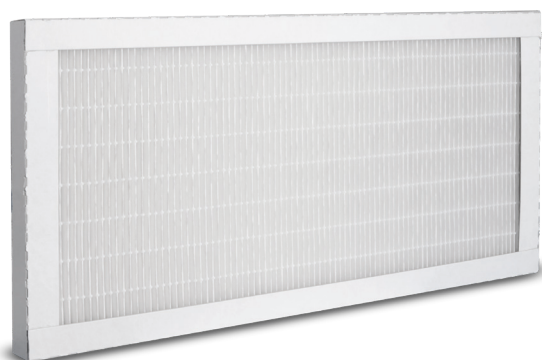

F7 is classified as a fine filter according to EN 779:2012 norm and as ePM<sub>1</sub> 55% in accordance with new standard ISO 16890.

Code	Filter class	Dimensions [mm]
HRQ-PremAir-FILT-F7	ISO ePM1 55% (old F7)	423x223x25



# Heat recovery ventilation unit with counterflow exchanger HRU-PremAIR

## Mobile application PremAIR

Mobile application for controlling a home ventilation unit HRU-PremAIR-450 by ALNOR.

It allows to monitor and control the unit via local network and Internet as well:

- Mode selection (Away, Home, Party, Boost, Auto and Standby)
- Temperature readouts
- Registering and displaying remote CO<sub>2</sub> and RH sensors readouts
- Fans efficiencies
- Defrost mode
- By-pass mode
- Filters conditions

Available for download in Google Play and App Store: PremAIR

Also via web browser: <https://premainr.alnor.pl/>



Screen shot:



# Heat recovery ventilation unit with counterflow exchanger

## HRU-PremAIR

### Energy class

Model	Sound level $L_{WA}$ dB(A) <sup>*</sup> [dB]	Air flow rate [m <sup>3</sup> /h]	Energy class			
			Manual control	Clock control	Central demand control (1 sensor)	Local demand control (2 sensor)
HRU-PremAIR-350	49	350	A	A	A	A+
HRU-PremAIR-350-CF	49	350	A	A	A	A+
HRU-PremAIR-350E	49	350	A	A	A	A+
HRU-PremAIR-350E-CF	49	350	A	A	A	A+
HRU-PremAIR-450	51	450	A	A	A	A+
HRU-PremAIR-450-CF	51	450	A	A	A	A
HRU-PremAIR-450E	51	450	A	A	A	A
HRU-PremAIR-450E-CF	51	450	A	A	A	A
HRU-PremAIR-500	49	500	A	A	A	A
HRU-PremAIR-500-CF	49	500	A	A	A	A

