

Cassette 4 Ways FCU DC

Service manual

MUCS-W7



Two-pipe Four-way Cassette DC Fan Coil Unit

1. External Appearance	2
2. Features	2
3. Product lineup	3
4. Accessories	4
5. Specifications	5
6. Capacity Table	7
7. Sound Levels	22
8. Dimension	22
9. Service Spaces	24
10. Wiring Diagrams	28
11. Troubleshooting.....	27
12. Installation	29

1. External Appearance



2. Features

- 4-way air supply panel is standard, 360° air supply panel is optional.

360° Panel



- Unique design of the centrifugal fan ensures extra-quiet operation and high efficiency.
- Wireless remote control with LED display, wired control is optional.
- Safety grill for safety maintenance.

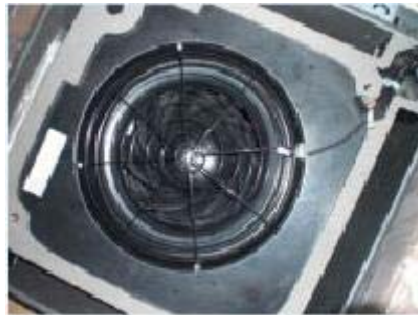

- Built-in drain water pump with 750mm pumping head.

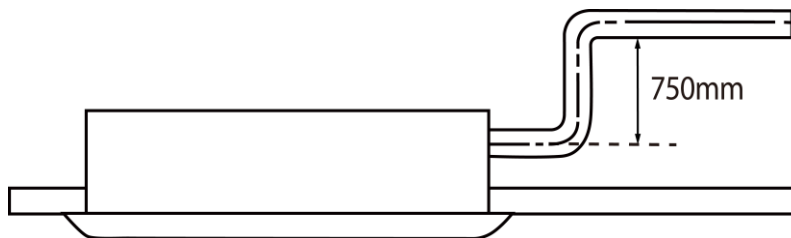

- Optional extended drainage pan for protecting your ceiling better.
- Four speed motor with one reserved for more choice.
- Fresh air provision makes life healthier and more comfortable.



- Excellent efficiency
DC FCU adopt the brushless DC motor, the DC motor efficiency is up to 90%. In contrast with the original FCU, DC FCU power consumption can be reduced by more than 30%.

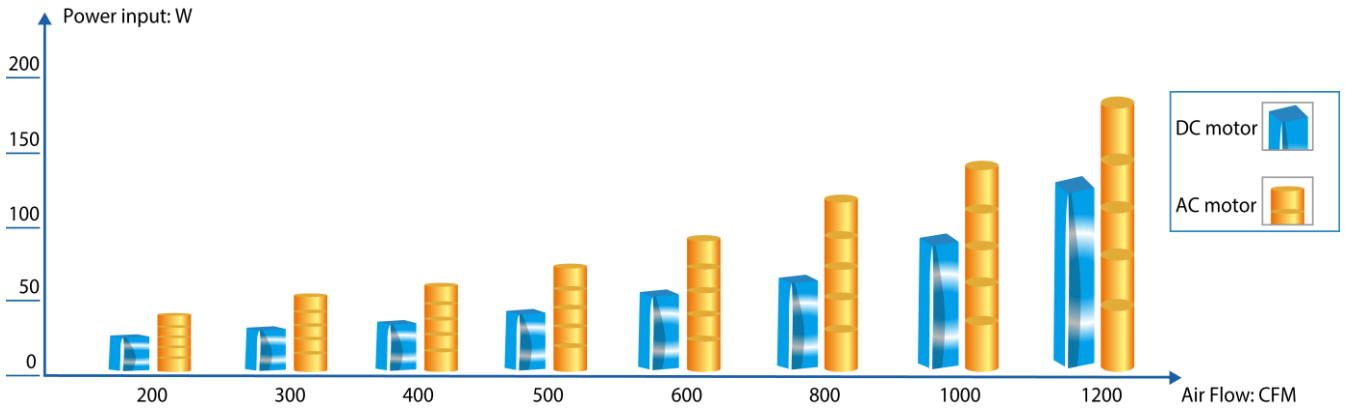

- DC brushless motor
The motor uses fully enclosed structure design, it is an energy-saving of high operating efficiency and durable motor. The motor bearing can operate 80,000 hours continuously and easy for maintenance.













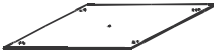

- Low noise
Advanced 3-D spiral fan design reduces air resistance and operating sound. The motor bearing with unique design makes less operation vibration.

3. Product Lineup

Type	20	24	36
4-way cassette (MUCS-W7)	●	●	●

4. Accessories

4.1 Standard accessories

Accessory name	Qty.	Shape	Usage
Owner's & installation manual	1	/	-
Installation paper board	1		-
Bolt M6	4		-
Tubing& Fittings	2		Soundproof / insulation sheath
Drainpipe Fittings	1		Out-let pipe
	1		Out-let pipe sheath
	1		Out-let pipe clasp
	5		Tightening band
Remote controller& Its Frame	1		Remote controller R05/BGE-20
	1		Frame
	2		Mounting screw (ST2.9x10-C-H)
	2		Alkaline dry batteries
Remote controller manual	1		-

4.2 Optional accessories

Accessory name	Qty.	Shape	Usage
Wired controller KJR-29B (CL92869)	1		Wired control
Wired controller KJR-12B/D (CL92905)	1		Wired control
Central controller CCM30 (CL92871)			Central control
Central controller CCM03 (CL92911)	1		Central control
3-way valve (CO05506 + CO05509)	1		3-way valve

5. Specifications

Model			(none)	MUCS-20-W7	(none)	
Power supply		V/Ph/Hz	220-240/1/50			
Air flow (H/M/L)		m ³ /h	1175/987/768	1229/1020/810	1451/1146/1012	
		CFM	691/580/451	722/600/476	853/674/595	
Cooling ¹	Capacity (H/M/L)	kW	5.93/5.3/4.4	6.12/5.45/4.6	7.52/6.46/5.89	
	Water flow rate(H/M/L)	m ³ /h	1.05/0.92/0.77	1.10/0.96/0.81	1.37/1.18/1.07	
	Water pressure drop(H/M/L)	kPa	19.2/15.4/11	21.3/21.3/12.4	20.1/15.3/12.6	
	Power input(H/M/L)	W	41/27/17	49/31/20	68/37/30	
Heating ²	Capacity (H/M/L)	kW	6.06/6.35/5.32	6.27/6.53/5.43	7.88/7.48/6.76	
	Water flow rate(H/M/L)	m ³ /h	1.30/1.14/1.13	1.39/1.20/1.00	1.66/1.39/1.25	
	Water pressure drop(H/M/L)	kPa	25.9/20.1/19.9	30/22.7/16.3	26.7/18.8/15.6	
	Power input(H/M/L)	W	42/28/17	44/32/19	66/37/28	
Heating ³	Capacity (H/M/L)	kW	8.42/7.37/6.06	8.62/7.49/6.27	10.37/8.72/7.88	
	Water flow rate(H/M/L)	m ³ /h	1.06/0.92/0.76	1.10/0.96/0.81	1.37/1.18/1.07	
	Water pressure drop(H/M/L)	kPa	16.9/12.7/8.6	19.1/14.8/10.6	18.2/13.6/11.1	
	Power input(H/M/L)	W	42/28/17	49/31/19	67/37/28	
Sound pressure level (H/M/L)		dB(A)	43/39/33	44/40/34	45/40/37	
Rated current		A	0.4	0.4	0.6	
Fan motor	Type		DC motor	DC motor	DC motor	
	Quantity		1	1	1	
	Brand		Panasonic	Panasonic	Panasonic	
	Model		WZDK80-38G	WZDK80-38G	WZDK90-38G	
Fan	Type		Centrifugal, forward-curved blades	Centrifugal, forward-curved blades	Centrifugal, forward-curved blades	
	Quantity		1	1	1	
Coil	Row		2	2	2	
	Max. Working pressure	MPa	1.6	1.6	1.6	
	Coil length x height		mm	1960x168	1960x168	1960x252
	Fin type			Hydrophilic aluminum	Hydrophilic aluminum	Hydrophilic aluminum
	Number of circuits			8	8	12
	Fin spacing			1.45	1.45	1.45
	Diameter			Φ7	Φ7	Φ7
Panel	Net dimensions (W×H×D)		mm	950×45×950	950×45×950	950×45×950
	Packing size (W×H×D)		mm	1035×90×1035	1035×90×1035	1035×90×1035
	Net weight		kg	6	6	6
	Gross weight		kg	9	9	9
Body	Net dimensions (W×H×D)		mm	840×230×840	840×230×840	840×300×840
	Packing size (W×H×D)		mm	900×260×900	900×260×900	900×330×900
	Net weight		kg	23	23	27
	Gross weight		kg	28	28	33
Pipe connection	Water inlet/outlet pipe		inch	RC3/4	RC3/4	RC3/4
	Drain pipe		mm	ODΦ32	ODΦ32	ODΦ32

Notes: 1. H: High fan speed; M: Medium fan speed; L: Low fan speed.

2. Cooling mode (2 and 4-pipe coil): entering air temperature 27°C DB/1 9°C WB, entering/leaving water temperature 7°C /12°C, high fan speed.

3. Heating mode (1) : (2-pipe coil): entering air temperature 20° C DB, entering/leaving water temperature 45/40° C, high fan speed.

4. Heating mode (2) : (2-pipe coil): entering air temperature 20° C DB, enter water teperature/water flow 50°C/*(same water flow as in standard rating condition in cooling)

Model		(none)	MUCS-24-W7	MUCS-36-W7	
Power supply		V/Ph/Hz	220-240/1/50		
Air flow (H/M/L)		m ³ /h	1530/1224/1101	1581/1371/1236	
		CFM	900/720/647	930/806/727	
Cooling ¹	Capacity (H/M/L)	kW	7.84/6.84/6.35	7.87/7.12/6.67	
	Water flow rate(H/M/L)	m ³ /h	1.43/1.24/1.13	1.44/1.28/1.22	
	Water pressure drop(H/M/L)	kPa	22/17/14.1	22.3/18.1/16.3	
	Power input(H/M/L)	W	75/42/34	85/59/45	
Heating ²	Capacity (H/M/L)	kW	8.49/8/7.35	9.16/8.54/7.9	
	Water flow rate(H/M/L)	m ³ /h	1.71/1.45/1.33	1.73/1.57/1.46	
	Water pressure drop(H/M/L)	kPa	28.1/20.7/17.4	28.8/24/20.7	
	Power input(H/M/L)	W	76/43/33	86/59/45	
Heating ³	Capacity (H/M/L)	kW	10.86/9.24/8.49	10.92/9.84/9.16	
	Water flow rate(H/M/L)	m ³ /h	1.43/1.24/1.13	1.44/1.28/1.22	
	Water pressure drop(H/M/L)	kPa	19.9/15.2/12.6	20/16.2/14.7	
	Power input(H/M/L)	W	76/42/33	85/58/45	
Sound pressure level (H/M/L)		dB(A)	46/42/39	48/44/41	
Rated current		A	0.6	0.7	
Fan motor	Type		DC motor	DC motor	
	Quantity		1	1	
	Brand		Panasonic	Panasonic	
	Model		WZDK90-38G	WZDK90-38G	
Fan	Type		Centrifugal, forward-curved blades	Centrifugal, forward-curved blades	
	Quantity		1	1	
Coil	Row		2	2	
	Max. Working pressure	MPa	1.6	1.6	
	Coil length x height		mm	1960x252	1960x252
	Fin type		Hydrophilic aluminum	Hydrophilic aluminum	
	Number of circuits		12	12	
	Fin spacing		1.45	1.45	
	Diameter		Φ7	Φ7	
Panel	Net dimensions (W×H×D)		mm	950×45×950	
	Packing size (W×H×D)		mm	1035×90×1035	
	Net weight		kg	6	
	Gross weight		kg	9	
Body	Net dimensions (W×H×D)		mm	840×300×840	
	Packing size (W×H×D)		mm	900×330×900	
	Net weight		kg	27	
	Gross weight		kg	33	
Pipe connection	Water inlet/outlet pipe		inch	RC3/4	
	Drain pipe		mm	ODΦ32	

Notes:

1. H: High fan speed; M: Medium fan speed; L: Low fan speed.
2. Cooling mode (2 and 4-pipe coil): entering air temperature 27°C DB/1 9°C WB, entering/leaving water temperature 7°C /12°C, high fan speed.
3. Heating mode (1) : (2-pipe coil): entering air temperature 20° C DB, entering/leaving water temperature 45/40° C, high fan speed.
4. Heating mode (2) : (2-pipe coil): entering air temperature 20° C DB, enter water teperature/water flow 50°C/*(same water flow as in standard rating condition in cooling)

6. Capacity Table

Cooling Capacity Table

		(none)																				
EWT	ΔT	Indoor temp (W.B.)	Indoor temperature (D.B.)																			
			21				23				25				27				29			
[°C]	[°C]	[°C]	[kW]	[kW]	[m ³ /h]	[kPa]	[kW]	[kW]	[m ³ /h]	[kPa]	[kW]	[kW]	[m ³ /h]	[kPa]	[kW]	[kW]	[m ³ /h]	[kPa]	[kW]	[kW]	[m ³ /h]	[kPa]
5	3	15	4.95	3.85	1.42	25.62	4.92	4.44	1.41	25.39	5.04	5.04	1.44	26.45	5.57	5.57	1.59	31.41	6.1	6.1	1.75	36.8
		17	6.44	3.75	1.84	40.34	6.41	4.34	1.84	40.01	6.36	4.92	1.82	39.55	6.14	5.41	1.76	37.22	6.19	6.02	1.77	37.73
		19	8.05	3.64	2.31	59.54	8.02	4.23	2.3	59.03	7.98	4.81	2.29	58.54	7.87	5.36	2.26	57.22	7.65	5.86	2.19	54.39
		20	8.91	3.58	2.56	70.95	8.87	4.17	2.55	70.45	8.83	4.76	2.54	69.86	8.76	5.32	2.52	68.93	8.57	5.84	2.46	66.39
	4	15	4.56	3.68	0.98	13.58	4.57	4.28	0.98	13.67	4.85	4.85	1.04	15.11	5.39	5.39	1.16	18.06	5.92	5.92	1.27	21.24
		17	6.05	3.57	1.3	21.98	6.02	4.16	1.29	21.8	5.98	4.74	1.28	21.56	5.82	5.26	1.25	20.57	5.97	5.92	1.28	21.55
		19	7.66	3.46	1.65	33.01	7.62	4.05	1.64	32.72	7.59	4.64	1.63	32.46	7.5	5.2	1.61	31.84	7.25	5.68	1.56	30.03
		20	8.51	3.4	1.83	39.56	8.48	4	1.82	39.29	8.44	4.58	1.81	38.96	8.38	5.15	1.8	38.5	8.18	5.67	1.76	36.97
	5	15	4.15	3.49	0.71	7.89	4.3	4.16	0.74	8.39	4.68	4.68	0.8	9.68	5.21	5.21	0.89	11.63	5.75	5.75	0.99	13.73
		17	5.64	3.39	0.97	13.29	5.62	3.98	0.96	13.19	5.59	4.57	0.96	13.08	5.51	5.13	0.94	12.76	5.78	5.78	0.99	13.85
		19	7.26	3.29	1.25	20.43	7.22	3.87	1.24	20.25	7.19	4.46	1.23	20.08	7.12	5.03	1.22	19.77	6.88	5.52	1.18	18.66
		20	8.1	3.22	1.39	24.67	8.07	3.82	1.39	24.51	8.03	4.41	1.38	24.3	7.98	4.98	1.37	24.04	7.81	5.5	1.34	23.14
6	15	3.78	3.33	0.54	4.23	4.06	4.05	0.58	5.19	4.49	4.49	0.64	6.51	5.03	5.03	0.72	8	5.57	5.57	0.8	9.52	
	17	5.21	3.2	0.75	8.49	5.19	3.8	0.74	8.45	5.18	4.39	0.74	8.4	5.24	5.01	0.75	8.59	5.58	5.58	0.8	9.57	
	19	6.84	3.11	0.98	13.48	6.8	3.69	0.97	13.35	6.77	4.28	0.97	13.25	6.72	4.86	0.96	13.07	6.52	5.37	0.93	12.43	
	20	7.69	3.05	1.1	16.43	7.66	3.64	1.1	16.33	7.62	4.23	1.09	16.19	7.58	4.81	1.08	16.03	7.43	5.34	1.06	15.52	
7	3	15	3.81	3.34	1.09	16.13	3.99	3.99	1.14	17.43	4.48	4.48	1.28	21.26	5.02	5.02	1.44	25.87	5.56	5.56	1.59	30.83
		17	5.28	3.23	1.51	28.2	5.26	3.83	1.51	28	5.23	4.41	1.5	27.75	5.18	4.98	1.48	27.3	5.56	5.56	1.59	30.85
		19	6.89	3.13	1.98	44.74	6.85	3.72	1.97	44.28	6.82	4.3	1.96	43.9	6.77	4.88	1.94	43.38	6.51	5.36	1.87	40.48
		20	7.73	3.06	2.22	54.65	7.7	3.66	2.21	54.27	7.66	4.24	2.2	53.77	7.62	4.83	2.19	53.27	7.43	5.34	2.13	50.94
	4	15	3.45	3.19	0.74	8.34	3.78	3.78	0.81	9.72	4.3	4.3	0.92	12.1	4.84	4.84	1.04	14.81	5.38	5.38	1.16	17.73
		17	4.86	3.05	1.04	14.89	4.85	3.65	1.04	14.82	4.83	4.24	1.04	14.72	4.94	4.88	1.06	15.32	5.38	5.38	1.16	17.74
		19	6.48	2.95	1.39	24.36	6.44	3.54	1.38	24.1	6.41	4.13	1.38	23.89	6.37	4.71	1.37	23.63	6.17	5.22	1.33	22.41
		20	7.32	2.89	1.57	30.03	7.29	3.49	1.57	29.83	7.25	4.07	1.56	29.55	7.21	4.66	1.55	29.28	7.07	5.19	1.52	28.31
	5	15	3.17	3.07	0.55	4.54	3.58	3.58	0.62	5.99	4.12	4.12	0.71	7.68	4.66	4.66	0.8	9.48	5.2	5.2	0.89	11.41
		17	4.41	2.87	0.76	8.62	4.41	3.47	0.76	8.63	4.47	4.09	0.77	8.81	4.74	4.74	0.81	9.73	5.2	5.2	0.89	11.42
		19	6.05	2.78	1.04	14.73	6.01	3.36	1.03	14.56	5.98	3.95	1.03	14.45	5.93	5	1.05	19.2	5.8	5.07	1	13.73
		20	6.89	2.71	1.18	18.39	6.86	3.31	1.18	18.26	6.82	3.9	1.17	18.08	6.79	4.48	1.17	17.94	6.68	5.04	1.15	17.46
6	15	2.93	2.93	0.42	2	3.39	3.39	0.49	3.17	3.93	3.93	0.56	4.95	4.48	4.48	0.64	6.45	5.02	5.02	0.72	7.87	
	17	3.92	2.67	0.56	4.93	3.97	3.29	0.57	5.07	4.18	3.97	0.6	5.65	4.53	4.53	0.65	6.58	5.03	5.03	0.72	7.87	
	19	5.6	2.59	0.8	9.43	5.55	3.18	0.8	9.31	5.53	3.77	0.79	9.26	5.51	4.36	0.79	9.2	5.46	4.93	0.78	9.04	
	20	6.45	2.53	0.92	11.99	6.41	3.13	0.92	11.89	6.38	3.72	0.91	11.77	6.35	4.31	0.91	11.69	6.26	4.87	0.9	11.42	
9	3	15	2.87	2.87	0.82	9.8	3.38	3.38	0.97	12.94	3.93	3.93	1.13	16.72	4.47	4.47	1.28	20.88	5.01	5.01	1.44	25.4
		17	4.04	2.71	1.16	17.55	4.05	3.32	1.16	17.61	4.11	3.94	1.18	18.06	4.47	4.47	1.28	20.89	5.01	5.01	1.44	25.42
		19	5.67	2.62	1.63	31.39	5.62	3.21	1.61	30.97	5.6	3.8	1.61	30.73	5.57	4.38	1.6	30.44	5.45	4.93	1.56	29.35
		20	6.5	2.56	1.87	39.84	6.47	3.15	1.86	39.51	6.43	3.74	1.85	39.09	6.4	4.33	1.84	38.76	6.32	4.89	1.81	37.92
	4	15	2.66	2.66	0.57	5.19	3.2	3.2	0.69	7.21	3.75	3.75	0.81	9.43	4.29	4.29	0.92	11.88	4.83	4.83	1.04	14.54
		17	3.57	2.53	0.77	8.68	3.62	3.15	0.78	8.89	3.85	3.84	0.83	9.89	4.29	4.29	0.92	11.88	4.84	4.84	1.04	14.54
		19	5.22	2.44	1.12	16.57	5.18	3.03	1.11	16.33	5.16	3.62	1.11	16.24	5.14	4.21	1.1	16.13	5.11	4.79	1.1	15.99
		20	6.06	2.38	1.3	21.41	6.03	2.98	1.3	21.21	5.99	3.57	1.29	20.98	5.97	4.16	1.28	20.83	5.91	4.73	1.27	20.46
	5	15	2.46	2.46	0.42	2.1	3.01	3.01	0.52	4.11	3.57	3.57	0.61	5.9	4.11	4.11	0.71	7.54	4.66	4.66	0.8	9.3
		17	3.1	2.34	0.53	4.44	3.28	3.01	0.56	5.04	3.63	3.63	0.62	6.09	4.11	4.11	0.71	7.55	4.66	4.66	0.8	9.31
		19	4.74	2.25	0.81	9.56	4.7	2.84	0.81	9.44	4.7	3.45	0.81	9.45	4.7	4.05	0.81	9.45	4.86	4.69	0.83	9.98
		20	5.61	2.21	0.96	12.74	5.57	2.8	0.96	12.58	5.53	3.39	0.95	12.45	5.52	3.98	0.95	12.4	5.48	4.56	0.94	12.23
6	15	2.26	2.26	0.32	1.37	2.83	2.83	0.4	1.88	3.38	3.38	0.48	3.4	3.93	3.93	0.56	5.01	4.48	4.48	0.64	6.36	
	17	2.67	2.17	0.38	1.66	3	2.9	0.43	2.27	3.42	3.42	0.49	3.54	3.93	3.93	0.56	5.02	4.48	4.48	0.64	6.37	
	19	4.23	2.06	0.61	5.74	4.2	2.65	0.6	5.67	4.21	3.26	0.6	5.71	4.34	3.91	0.62	6.03	4.62	4.6	0.66	6.7	
	20	5.12	2.02	0.73	7.97	5.06	2.61	0.73	7.82	5.04	3.2	0.72	7.78	5.05	3.8	0.72	7.79	5.06	4.4	0.73	7.82	

(Continued)

		(none)																							
EWT	ΔT	Indoor temp (W.B.)	Indoor temperature (D.B.)																						
			21				23				25				27				29						
			TC	SC	WF	WPD	TC	SC	WF	WPD	TC	SC	WF	WPD	TC	SC	WF	WPD	TC	SC	WF	WPD			
[°C]	[°C]	[°C]	[kW]	[kW]	[m ³ /h]	[kPa]	[kW]	[kW]	[m ³ /h]	[kPa]	[kW]	[kW]	[m ³ /h]	[kPa]	[kW]	[kW]	[m ³ /h]	[kPa]	[kW]	[kW]	[m ³ /h]	[kPa]			
11	3	15	2.27	2.27	0.65	6.48	2.82	2.82	0.81	9.39	3.37	3.37	0.97	12.71	3.92	3.92	1.12	16.42	4.46	4.46	1.28	20.51			
		17	2.73	2.2	0.78	8.89	2.93	2.88	0.84	10.03	3.37	3.37	0.97	12.72	3.92	3.92	1.12	16.43	4.46	4.46	1.28	20.52			
		19	4.34	2.1	1.24	19.5	4.3	2.69	1.23	19.25	4.31	3.3	1.24	19.3	4.31	3.89	1.24	19.32	4.51	4.51	1.3	20.91			
		20	5.2	2.05	1.49	26.7	5.16	2.64	1.48	26.3	5.13	3.23	1.47	26.03	5.11	3.83	1.47	25.92	5.07	4.41	1.46	25.55			
	4	15	2.08	2.08	0.45	2.72	2.64	2.64	0.57	5.1	3.19	3.19	0.69	7.08	3.74	3.74	0.8	9.26	4.29	4.29	0.92	11.67			
		17	2.34	2.05	0.5	3.94	2.7	2.7	0.58	5.31	3.19	3.19	0.69	7.09	3.74	3.74	0.81	9.27	4.29	4.29	0.92	11.67			
		19	3.85	1.92	0.83	9.72	3.81	2.51	0.82	9.56	3.84	3.12	0.83	9.67	3.98	3.77	0.86	10.27	4.31	4.31	0.93	11.8			
		20	4.72	1.87	1.02	13.7	4.67	2.46	1	13.46	4.65	3.06	1	13.4	4.66	3.66	1	13.43	4.67	4.26	1	13.48			
	5	15	1.89	1.89	0.32	1.31	2.45	2.45	0.42	2.25	3.01	3.01	0.52	4.22	3.56	3.56	0.61	5.81	4.11	4.11	0.71	7.41			
		17	2.04	1.94	0.35	1.42	2.49	2.49	0.43	2.36	3.01	3.01	0.52	4.23	3.56	3.56	0.61	5.82	4.11	4.11	0.71	7.41			
		19	3.31	1.72	0.57	5.11	3.32	2.33	0.57	5.11	3.42	2.97	0.59	5.4	3.71	3.67	0.64	6.24	4.12	4.12	0.71	7.45			
		20	4.2	1.68	0.72	7.68	4.16	2.28	0.72	7.55	4.14	2.87	0.71	7.49	4.19	3.49	0.72	7.64	4.36	4.14	0.75	8.19			
	6	15	1.68	1.68	0.24	0.96	2.26	2.26	0.32	1.29	2.82	2.82	0.41	1.99	3.38	3.38	0.48	3.59	3.93	3.93	0.56	4.99			
		17	1.77	1.77	0.25	1.01	2.28	2.28	0.33	1.3	2.83	2.83	0.41	1.99	3.38	3.38	0.48	3.59	3.93	3.93	0.56	5			
		19	2.78	1.53	0.4	1.91	2.81	2.15	0.4	1.94	3.09	2.85	0.44	2.75	3.48	3.48	0.5	3.88	3.94	3.94	0.56	5.01			
		20	3.65	1.49	0.52	4.32	3.61	2.08	0.52	4.21	3.61	2.68	0.52	4.21	3.81	3.35	0.55	4.7	4.1	4.05	0.59	5.4			
	13	3	15	1.71	1.71	0.49	3.75	2.27	2.27	0.65	6.37	2.82	2.82	0.81	9.23	3.37	3.37	0.97	12.49	3.91	3.91	1.12	16.14		
			17	1.75	1.75	0.5	3.96	2.27	2.27	0.65	6.38	2.82	2.82	0.81	9.23	3.37	3.37	0.97	12.5	3.91	3.91	1.12	16.15		
			19	2.91	1.58	0.84	9.75	2.93	2.19	0.84	9.83	3.03	2.83	0.87	10.45	3.39	3.39	0.97	12.64	3.92	3.92	1.12	16.16		
			20	3.79	1.54	1.09	15.3	3.73	2.12	1.07	14.84	3.73	2.73	1.07	14.84	3.78	3.34	1.09	15.21	3.99	3.99	1.15	16.71		
4		15	1.51	1.51	0.33	1.27	2.08	2.08	0.45	2.93	2.64	2.64	0.57	5.04	3.19	3.19	0.69	6.96	3.74	3.74	0.8	9.1			
		17	1.53	1.53	0.33	1.28	2.08	2.08	0.45	2.94	2.64	2.64	0.57	5.04	3.19	3.19	0.69	6.97	3.74	3.74	0.8	9.11			
		19	2.41	1.41	0.52	4.29	2.45	2.02	0.53	4.41	2.76	2.73	0.59	5.44	3.2	3.2	0.69	7	3.74	3.74	0.8	9.11			
		20	3.27	1.36	0.7	7.23	3.21	1.94	0.69	7.04	3.21	2.55	0.69	7.04	3.43	3.22	0.74	7.88	3.78	3.78	0.81	9.28			
5		15	-	-	-	-	1.89	1.89	0.33	1.25	2.45	2.45	0.42	2.45	3.01	3.01	0.52	4.25	3.56	3.56	0.61	5.72			
		17	-	-	-	-	1.89	1.89	0.33	1.25	2.45	2.45	0.42	2.45	3.01	3.01	0.52	4.25	3.56	3.56	0.61	5.72			
		19	-	-	-	-	2.1	1.9	0.36	1.48	2.52	2.52	0.43	2.7	3.01	3.01	0.52	4.26	3.56	3.56	0.61	5.73			
		20	-	-	-	-	2.67	1.76	0.46	3.24	2.8	2.41	0.48	3.65	3.16	3.13	0.54	4.66	3.58	3.58	0.62	5.79			
6		15	-	-	-	-	1.69	1.69	0.24	0.91	2.26	2.26	0.32	1.23	2.82	2.82	0.41	2.16	3.38	3.38	0.48	3.69			
		17	-	-	-	-	1.69	1.69	0.24	0.91	2.26	2.26	0.32	1.23	2.82	2.82	0.41	2.16	3.38	3.38	0.48	3.69			
		19	-	-	-	-	1.81	1.8	0.26	0.98	2.3	2.3	0.33	1.26	2.83	2.83	0.41	2.16	3.38	3.38	0.49	3.69			
		20	-	-	-	-	2.13	1.58	0.31	1.14	2.49	2.3	0.36	1.45	2.92	2.92	0.42	2.44	3.39	3.39	0.49	3.73			
15		3	15	-	-	-	-	1.71	1.71	0.49	3.8	2.26	2.26	0.65	6.26	2.82	2.82	0.81	9.07	3.36	3.36	0.97	12.28		
			17	-	-	-	-	1.71	1.71	0.49	3.8	2.26	2.26	0.65	6.27	2.82	2.82	0.81	9.07	3.36	3.36	0.97	12.28		
			19	-	-	-	-	1.78	1.78	0.51	4.15	2.26	2.26	0.65	6.27	2.82	2.82	0.81	9.08	3.37	3.37	0.97	12.29		
			20	-	-	-	-	2.29	1.63	0.66	6.37	2.42	2.28	0.7	7.05	2.84	2.84	0.82	9.2	3.37	3.37	0.97	12.29		
	4	15	-	-	-	-	1.51	1.51	0.33	1.21	2.08	2.08	0.45	3.08	2.64	2.64	0.57	4.96	3.19	3.19	0.69	6.84			
		17	-	-	-	-	1.51	1.51	0.33	1.21	2.08	2.08	0.45	3.09	2.64	2.64	0.57	4.97	3.19	3.19	0.69	6.85			
		19	-	-	-	-	1.55	1.55	0.33	1.25	2.08	2.08	0.45	3.09	2.64	2.64	0.57	4.97	3.19	3.19	0.69	6.85			
		20	-	-	-	-	1.8	1.47	0.39	1.93	2.16	2.16	0.47	3.41	2.65	2.65	0.57	5	3.19	3.19	0.69	6.85			
	5	15	-	-	-	-	-	-	-	-	1.89	1.89	0.33	1.2	2.45	2.45	0.42	2.63	3.01	3.01	0.52	4.22			
		17	-	-	-	-	-	-	-	-	1.89	1.89	0.33	1.2	2.45	2.45	0.42	2.63	3.01	3.01	0.52	4.22			
		19	-	-	-	-	-	-	-	-	1.89	1.89	0.33	1.2	2.45	2.45	0.42	2.63	3.01	3.01	0.52	4.22			
		20	-	-	-	-	-	-	-	-	1.94	1.94	0.33	1.25	2.45	2.45	0.42	2.64	3.01	3.01	0.52	4.22			
	6	15	-	-	-	-	-	-	-	-	1.69	1.69	0.24	0.87	2.26	2.26	0.32	1.2	2.82	2.82	0.41	2.33			
		17	-	-	-	-	-	-	-	-	1.69	1.69	0.24	0.87	2.26	2.26	0.32	1.2	2.82	2.82	0.41	2.33			
		19	-	-	-	-	-	-	-	-	1.69	1.69	0.24	0.87	2.26	2.26	0.33	1.2	2.82	2.82	0.41	2.33			
		20	-	-	-	-	-	-	-	-	1.71	1.71	0.25	0.88	2.26	2.26	0.33	1.2	2.82	2.82	0.41	2.33			

Abbreviations:

EWT: Enter Water Temp. (°C) Δt: Temperature Difference (°C) DB: Dry Bulb Temp. (°C) WF: Water Flow (m³/h)
 WB: Wet Bulb Temp. (°C) TC: Total Cooling Capacity (kW) SC: Sensible Cooling Capacity (kW) WPD: Water Pressure Drop (kPa)

MUCS-20-W7																							
EWT	ΔT	Indoor temp (W.B.)	Indoor temperature (D.B.)																				
			21				23				25				27				29				
			TC	SC	WF	WPD	TC	SC	WF	WPD	TC	SC	WF	WPD	TC	SC	WF	WPD	TC	SC	WF	WPD	
°C	°C	°C	kW	kW	m³/h	kPa	kW	kW	m³/h	kPa	kW	kW	m³/h	kPa	kW	kW	m³/h	kPa	kW	kW	m³/h	kPa	
5	3	15	5.06	3.95	1.45	26.66	5.04	4.56	1.44	26.45	5.18	5.18	1.48	27.75	5.72	5.72	1.64	32.86	6.27	6.27	1.8	38.52	
		17	6.59	3.84	1.89	42.01	6.56	4.45	1.88	41.67	6.52	5.05	1.87	41.27	6.32	5.57	1.81	39.21	6.35	6.19	1.82	39.36	
		19	8.25	3.73	2.37	62.04	8.21	4.33	2.36	61.51	8.17	4.93	2.34	61.01	8.08	5.51	2.32	59.83	7.83	6.01	2.25	56.71	
		20	9.12	3.66	2.62	73.93	9.08	4.27	2.61	73.43	9.04	4.87	2.6	72.82	8.98	5.46	2.58	71.94	8.79	5.99	2.53	69.39	
	4	15	4.66	3.77	1	14.11	4.69	4.4	1.01	14.24	4.99	4.99	1.07	15.86	5.53	5.53	1.19	18.89	6.08	6.08	1.31	22.22	
		17	6.19	3.66	1.33	22.86	6.16	4.27	1.32	22.68	6.13	4.87	1.31	22.48	5.98	5.41	1.28	21.56	6.13	6.09	1.31	22.48	
		19	7.84	3.55	1.68	34.37	7.8	4.15	1.68	34.07	7.77	4.75	1.67	33.79	7.69	5.34	1.65	33.25	7.43	5.83	1.6	31.32	
		20	8.71	3.48	1.87	41.18	8.68	4.09	1.86	40.92	8.64	4.69	1.86	40.57	8.58	5.29	1.84	40.14	8.39	5.82	1.8	38.63	
	5	15	4.24	3.58	0.73	8.2	4.41	4.27	0.76	8.75	4.8	4.8	0.82	10.11	5.35	5.35	0.92	12.15	5.9	5.9	1.01	14.36	
		17	5.77	3.47	0.99	13.81	5.75	4.08	0.99	13.72	5.72	4.69	0.98	13.61	5.65	5.27	0.97	13.33	5.92	5.92	1.02	14.46	
		19	7.43	3.37	1.28	21.26	7.39	3.97	1.27	21.06	7.36	4.57	1.26	20.89	7.3	5.17	1.25	20.62	7.08	5.68	1.22	19.57	
		20	8.29	3.3	1.42	25.66	8.26	3.91	1.42	25.51	8.22	4.51	1.41	25.29	8.18	5.11	1.4	25.05	8.02	5.66	1.38	24.24	
	6	15	3.87	3.42	0.55	4.53	4.16	4.16	0.6	5.52	4.6	4.6	0.66	6.84	5.16	5.16	0.74	8.37	5.72	5.72	0.82	9.95	
		17	5.33	3.28	0.76	8.82	5.31	3.9	0.76	8.78	5.3	4.5	0.76	8.73	5.37	5.15	0.77	8.96	5.73	5.73	0.82	9.99	
		19	7	3.18	1	14.02	6.96	3.78	1	13.88	6.93	4.39	0.99	13.77	6.88	4.99	0.98	13.62	6.7	5.52	0.96	13.03	
		20	7.87	3.11	1.13	17.09	7.84	3.73	1.12	16.98	7.8	4.33	1.12	16.83	7.76	4.93	1.11	16.69	7.63	5.49	1.09	16.23	
	7	3	15	3.9	3.43	1.12	16.76	4.09	4.09	1.17	18.19	4.6	4.6	1.32	22.24	5.15	5.15	1.48	27.06	5.71	5.71	1.64	32.26
			17	5.4	3.31	1.55	29.34	5.38	3.92	1.54	29.14	5.35	4.53	1.53	28.9	5.33	5.13	1.53	28.64	5.71	5.71	1.64	32.29
			19	7.06	3.2	2.03	46.59	7.01	3.81	2.01	46.11	6.98	4.41	2	45.71	6.94	5.01	1.99	45.27	6.72	5.53	1.93	42.78
			20	7.92	3.14	2.27	56.9	7.89	3.75	2.27	56.53	7.84	4.35	2.25	56.01	7.8	4.95	2.24	55.53	7.65	5.5	2.2	53.63
4		15	3.53	3.27	0.76	8.68	3.88	3.88	0.83	10.15	4.41	4.41	0.95	12.64	4.97	4.97	1.07	15.48	5.52	5.52	1.19	18.54	
		17	4.97	3.13	1.07	15.47	4.96	3.74	1.06	15.4	4.94	4.35	1.06	15.32	5.08	5.02	1.09	16.08	5.53	5.53	1.19	18.55	
		19	6.63	3.02	1.42	25.35	6.59	3.63	1.42	25.07	6.56	4.23	1.41	24.86	6.52	4.84	1.4	24.63	6.35	5.37	1.36	23.52	
		20	7.49	2.96	1.61	31.25	7.46	3.57	1.6	31.04	7.42	4.17	1.59	30.75	7.38	4.78	1.59	30.49	7.26	5.34	1.56	29.65	
5		15	3.25	3.15	0.56	4.83	3.67	3.67	0.63	6.28	4.23	4.23	0.73	8.02	4.79	4.79	0.82	9.9	5.34	5.34	0.92	11.93	
		17	4.51	2.94	0.77	8.95	4.51	3.56	0.78	8.96	4.58	4.2	0.79	9.18	4.86	4.86	0.83	10.15	5.34	5.34	0.92	11.94	
		19	6.19	2.84	1.06	15.32	6.15	3.45	1.06	15.13	6.12	4.05	1.05	15.01	6.12	5.18	1.1	21.3	5.96	5.22	1.02	14.35	
		20	7.05	2.78	1.21	19.13	7.02	3.39	1.21	18.99	6.98	3.99	1.2	18.8	6.95	4.6	1.19	18.65	6.85	5.17	1.18	18.26	
6		15	3	3	0.43	2.13	3.48	3.48	0.5	3.46	4.04	4.04	0.58	5.26	4.6	4.6	0.66	6.76	5.16	5.16	0.74	8.22	
		17	4.02	2.74	0.58	5.22	4.06	3.37	0.58	5.33	4.28	4.08	0.61	5.93	4.65	4.65	0.67	6.88	5.16	5.16	0.74	8.23	
		19	5.72	2.65	0.82	9.8	5.68	3.26	0.81	9.67	5.66	3.87	0.81	9.61	5.64	4.48	0.81	9.56	5.59	5.07	0.8	9.42	
		20	6.59	2.59	0.94	12.46	6.56	3.2	0.94	12.35	6.52	3.81	0.93	12.23	6.5	4.42	0.93	12.14	6.42	5	0.92	11.89	
9	3	15	2.94	2.94	0.84	10.22	3.47	3.47	0.99	13.53	4.03	4.03	1.16	17.48	4.59	4.59	1.32	21.84	5.14	5.14	1.48	26.59	
		17	4.13	2.78	1.18	18.22	4.14	3.41	1.19	18.3	4.21	4.05	1.21	18.82	4.59	4.59	1.32	21.85	5.15	5.15	1.48	26.6	
		19	5.8	2.68	1.66	32.67	5.75	3.29	1.65	32.21	5.73	3.89	1.64	31.96	5.7	4.5	1.63	31.69	5.6	5.07	1.61	30.79	
		20	6.65	2.62	1.91	41.46	6.62	3.23	1.9	41.12	6.58	3.83	1.89	40.68	6.55	4.44	1.88	40.34	6.5	5.03	1.87	39.79	
	4	15	2.73	2.73	0.59	5.45	3.28	3.28	0.7	7.53	3.85	3.85	0.83	9.85	4.41	4.41	0.95	12.42	4.96	4.96	1.07	15.2	
		17	3.66	2.59	0.79	9.04	3.7	3.23	0.8	9.23	3.95	3.94	0.85	10.31	4.41	4.41	0.95	12.42	4.96	4.96	1.07	15.21	
		19	5.34	2.5	1.15	17.22	5.29	3.1	1.14	16.96	5.28	3.72	1.13	16.87	5.26	4.32	1.13	16.78	5.26	4.93	1.13	16.78	
		20	6.2	2.44	1.33	22.27	6.17	3.05	1.33	22.05	6.13	3.66	1.32	21.81	6.1	4.26	1.31	21.66	6.06	4.86	1.3	21.37	
	5	15	2.53	2.53	0.43	2.29	3.09	3.09	0.53	4.39	3.66	3.66	0.63	6.17	4.22	4.22	0.73	7.88	4.78	4.78	0.82	9.73	
		17	3.18	2.4	0.55	4.7	3.36	3.09	0.58	5.27	3.72	3.72	0.64	6.36	4.22	4.22	0.73	7.89	4.78	4.78	0.82	9.73	
		19	4.84	2.3	0.83	9.91	4.8	2.91	0.83	9.79	4.81	3.53	0.83	9.8	4.81	4.15	0.83	9.83	4.98	4.82	0.86	10.42	
		20	5.73	2.26	0.99	13.24	5.69	2.86	0.98	13.06	5.66	3.47	0.97	12.93	5.64	4.08	0.97	12.88	5.6	4.68	0.96	12.73	
	6	15	2.32	2.32	0.33	1.4	2.9	2.9	0.42	2.02	3.47	3.47	0.5	3.68	4.04	4.04	0.58	5.28	4.6	4.6	0.66	6.66	
		17	2.72	2.23	0.39	1.73	3.07	2.98	0.44	2.46	3.51	3.51	0.5	3.82	4.04	4.04	0.58	5.28	4.6	4.6	0.66	6.66	
		19	4.31	2.1	0.62	5.96	4.29	2.72	0.61	5.89	4.3	3.34	0.62	5.92	4.45	4.01	0.64	6.28	4.73	4.73	0.68	7	
		20	5.23	2.06	0.75	8.26	5.17	2.67	0.74	8.11	5.15	3.28	0.74	8.07	5.16	3.9	0.74	8.08	5.18	4.52	0.74	8.14	

(Continued)

MUCS-20-W7																							
EWT	ΔT	Indoor temp (W.B.)	Indoor temperature (D.B.)																				
			21				23				25				27				29				
			TC	SC	WF	WPD	TC	SC	WF	WPD	TC	SC	WF	WPD	TC	SC	WF	WPD	TC	SC	WF	WPD	
°C	°C	°C	kW	kW	m ³ /h	kPa	kW	kW	m ³ /h	kPa	kW	kW	m ³ /h	kPa	kW	kW	m ³ /h	kPa	kW	kW	m ³ /h	kPa	
11	3	15	2.33	2.33	0.67	6.77	2.9	2.9	0.83	9.81	3.46	3.46	0.99	13.29	4.02	4.02	1.15	17.18	4.58	4.58	1.32	21.46	
		17	2.8	2.26	0.8	9.27	3	2.96	0.86	10.44	3.46	3.46	0.99	13.29	4.02	4.02	1.15	17.19	4.58	4.58	1.32	21.47	
		19	4.43	2.15	1.27	20.23	4.39	2.76	1.26	19.97	4.4	3.38	1.26	20.04	4.41	4	1.27	20.11	4.63	4.63	1.33	21.85	
		20	5.32	2.1	1.53	27.78	5.27	2.7	1.51	27.33	5.24	3.32	1.5	27.04	5.23	3.93	1.5	26.95	5.19	4.53	1.49	26.62	
	4	15	2.14	2.14	0.46	2.97	2.71	2.71	0.58	5.34	3.28	3.28	0.7	7.4	3.84	3.84	0.83	9.68	4.4	4.4	0.95	12.2	
		17	2.39	2.1	0.51	4.16	2.77	2.77	0.6	5.54	3.28	3.28	0.71	7.41	3.84	3.84	0.83	9.69	4.4	4.4	0.95	12.2	
		19	3.93	1.96	0.85	10.06	3.89	2.57	0.84	9.9	3.92	3.2	0.84	10.01	4.08	3.87	0.88	10.7	4.42	4.42	0.95	12.31	
		20	4.83	1.91	1.04	14.27	4.76	2.52	1.03	13.96	4.75	3.13	1.02	13.9	4.76	3.75	1.02	13.94	4.78	4.37	1.03	14.05	
	5	15	1.94	1.94	0.33	1.35	2.52	2.52	0.43	2.47	3.09	3.09	0.53	4.47	3.66	3.66	0.63	6.08	4.22	4.22	0.73	7.75	
		17	2.09	1.99	0.36	1.47	2.55	2.55	0.44	2.58	3.09	3.09	0.53	4.47	3.66	3.66	0.63	6.08	4.22	4.22	0.73	7.75	
		19	3.38	1.76	0.58	5.29	3.4	2.39	0.58	5.35	3.5	3.04	0.6	5.62	3.81	3.77	0.65	6.5	4.23	4.23	0.73	7.78	
		20	4.77	1.89	0.74	8.05	4.24	2.33	0.73	7.81	4.22	2.94	0.73	7.75	4.28	3.58	0.74	7.93	4.47	4.26	0.77	8.54	
	6	15	1.73	1.73	0.25	0.99	2.32	2.32	0.33	1.33	2.9	2.9	0.42	2.17	3.47	3.47	0.5	3.84	4.03	4.03	0.58	5.23	
		17	1.82	1.82	0.26	1.03	2.34	2.34	0.33	1.34	2.9	2.9	0.42	2.18	3.47	3.47	0.5	3.84	4.03	4.03	0.58	5.24	
		19	2.86	1.58	0.41	2.17	2.87	2.2	0.41	2.13	3.16	2.93	0.45	2.97	3.57	3.57	0.51	4.11	4.04	4.04	0.58	5.25	
		20	3.77	1.54	0.54	4.62	3.68	2.13	0.53	4.39	3.68	2.75	0.53	4.4	3.89	3.44	0.56	4.9	4.21	4.16	0.6	5.63	
	13	3	15	1.75	1.75	0.5	3.98	2.33	2.33	0.67	6.66	2.89	2.89	0.83	9.64	3.46	3.46	0.99	13.06	4.02	4.02	1.15	16.89
			17	1.79	1.79	0.51	4.18	2.33	2.33	0.67	6.66	2.89	2.89	0.83	9.65	3.46	3.46	0.99	13.07	4.02	4.02	1.15	16.89
			19	2.97	1.61	0.85	10.08	2.99	2.25	0.86	10.2	3.1	2.9	0.89	10.86	3.48	3.48	1	13.2	4.02	4.02	1.15	16.9
			20	3.87	1.57	1.11	15.85	3.8	2.17	1.09	15.43	3.8	2.79	1.09	15.36	3.87	3.43	1.11	15.8	4.1	4.1	1.18	17.46
4		15	1.55	1.55	0.33	1.3	2.14	2.14	0.46	3.18	2.71	2.71	0.58	5.27	3.27	3.27	0.7	7.28	3.84	3.84	0.83	9.52	
		17	1.57	1.57	0.34	1.32	2.14	2.14	0.46	3.18	2.71	2.71	0.58	5.27	3.28	3.28	0.71	7.28	3.84	3.84	0.83	9.52	
		19	2.48	1.44	0.53	4.51	2.51	2.08	0.54	4.59	2.82	2.81	0.61	5.66	3.28	3.28	0.71	7.31	3.84	3.84	0.83	9.53	
		20	3.34	1.38	0.72	7.51	3.28	1.99	0.71	7.28	3.29	2.62	0.71	7.32	3.51	3.31	0.76	8.19	3.88	3.88	0.84	9.69	
5		15	-	-	-	-	1.94	1.94	0.33	1.29	2.52	2.52	0.43	2.67	3.09	3.09	0.53	4.46	3.65	3.65	0.63	5.98	
		17	-	-	-	-	1.94	1.94	0.33	1.29	2.52	2.52	0.43	2.68	3.09	3.09	0.53	4.47	3.65	3.65	0.63	5.98	
		19	-	-	-	-	2.15	1.95	0.37	1.57	2.58	2.58	0.45	2.92	3.09	3.09	0.53	4.47	3.66	3.66	0.63	5.99	
		20	-	-	-	-	2.72	1.8	0.47	3.41	2.87	2.47	0.49	3.85	3.24	3.21	0.56	4.86	3.68	3.68	0.63	6.05	
6		15	-	-	-	-	1.73	1.73	0.25	0.94	2.32	2.32	0.33	1.27	2.9	2.9	0.42	2.36	3.47	3.47	0.5	3.91	
		17	-	-	-	-	1.73	1.73	0.25	0.94	2.32	2.32	0.33	1.27	2.9	2.9	0.42	2.36	3.47	3.47	0.5	3.91	
		19	-	-	-	-	1.85	1.85	0.27	1	2.36	2.36	0.34	1.3	2.9	2.9	0.42	2.37	3.47	3.47	0.5	3.91	
		20	-	-	-	-	2.17	1.62	0.31	1.17	2.54	2.36	0.37	1.54	2.99	2.99	0.43	2.65	3.48	3.48	0.5	3.94	
15		3	15	-	-	-	-	1.75	1.75	0.5	4	2.32	2.32	0.67	6.54	2.89	2.89	0.83	9.48	3.45	3.45	0.99	12.84
			17	-	-	-	-	1.75	1.75	0.5	4	2.32	2.32	0.67	6.55	2.89	2.89	0.83	9.49	3.45	3.45	0.99	12.85
			19	-	-	-	-	1.83	1.83	0.52	4.34	2.32	2.32	0.67	6.55	2.89	2.89	0.83	9.49	3.45	3.45	0.99	12.86
			20	-	-	-	-	2.34	1.68	0.67	6.64	2.48	2.34	0.71	7.33	2.91	2.91	0.84	9.6	3.46	3.46	0.99	12.86
	4	15	-	-	-	-	1.55	1.55	0.33	1.26	2.13	2.13	0.46	3.3	2.71	2.71	0.58	5.19	3.27	3.27	0.7	7.16	
		17	-	-	-	-	1.55	1.55	0.33	1.26	2.13	2.13	0.46	3.3	2.71	2.71	0.58	5.19	3.27	3.27	0.7	7.16	
		19	-	-	-	-	1.59	1.59	0.34	1.31	2.13	2.13	0.46	3.3	2.71	2.71	0.58	5.19	3.27	3.27	0.71	7.16	
		20	-	-	-	-	1.84	1.51	0.4	2.09	2.22	2.22	0.48	3.62	2.71	2.71	0.58	5.22	3.27	3.27	0.71	7.16	
	5	15	-	-	-	-	-	-	-	-	1.94	1.94	0.33	1.25	2.52	2.52	0.43	2.84	3.09	3.09	0.53	4.42	
		17	-	-	-	-	-	-	-	-	1.94	1.94	0.33	1.25	2.52	2.52	0.43	2.84	3.09	3.09	0.53	4.42	
		19	-	-	-	-	-	-	-	-	1.94	1.94	0.33	1.25	2.52	2.52	0.43	2.84	3.09	3.09	0.53	4.42	
		20	-	-	-	-	-	-	-	-	1.98	1.98	0.34	1.31	2.52	2.52	0.43	2.84	3.09	3.09	0.53	4.42	
	6	15	-	-	-	-	-	-	-	-	1.73	1.73	0.25	0.89	2.32	2.32	0.33	1.25	2.9	2.9	0.42	2.53	
		17	-	-	-	-	-	-	-	-	1.73	1.73	0.25	0.89	2.32	2.32	0.33	1.25	2.9	2.9	0.42	2.53	
		19	-	-	-	-	-	-	-	-	1.73	1.73	0.25	0.89	2.32	2.32	0.33	1.25	2.9	2.9	0.42	2.53	
		20	-	-	-	-	-	-	-	-	1.76	1.76	0.25	0.9	2.32	2.32	0.33	1.26	2.9	2.9	0.42	2.54	

Abbreviations:

EWT: Enter Water Temp. (°C) Δt: Temperature Difference (°C) DB: Dry Bulb Temp. (°C) WF: Water Flow (m³/h)
 WB: Wet Bulb Temp. (°C) TC: Total Cooling Capacity (kW) SC: Sensible Cooling Capacity (kW) WPD: Water Pressure Drop (kPa)

(none)

EWT	ΔT	Indoor temp (W.B.)	Indoor temperature (D.B.)																			
			21				23				25				27				29			
			TC	SC	WF	WPD	TC	SC	WF	WPD	TC	SC	WF	WPD	TC	SC	WF	WPD	TC	SC	WF	WPD
°C	°C	°C	kW	kW	m ³ /h	kPa	kW	kW	m ³ /h	kPa	kW	kW	m ³ /h	kPa	kW	kW	m ³ /h	kPa	kW	kW	m ³ /h	kPa
5	3	15	6.47	4.99	1.85	20.28	6.43	5.74	1.84	20.05	6.51	6.51	1.86	20.51	7.19	7.19	2.06	24.3	7.88	7.88	2.26	28.43
		17	8.42	4.87	2.41	31.83	8.38	5.63	2.4	31.57	8.28	6.35	2.37	30.95	7.99	6.97	2.29	29.08	8.07	7.76	2.31	29.62
		19	10.53	4.76	3.02	46.84	10.47	5.51	3	46.45	10.42	6.25	2.99	46.01	10.24	6.93	2.93	44.63	10	7.58	2.87	42.89
		20	11.64	4.69	3.34	55.77	11.59	5.44	3.32	55.36	11.53	6.19	3.31	54.9	11.42	6.9	3.28	53.96	11.17	7.55	3.2	51.95
	4	15	5.97	4.76	1.28	10.8	5.97	5.53	1.28	10.79	6.27	6.27	1.35	11.75	6.96	6.96	1.49	14.02	7.65	7.65	1.64	16.46
		17	7.91	4.65	1.7	17.42	7.88	5.4	1.69	17.28	7.8	6.13	1.67	16.98	7.55	6.77	1.62	16.06	7.77	7.62	1.67	16.87
		19	10.02	4.53	2.15	26.08	9.97	5.28	2.14	25.86	9.92	6.02	2.13	25.63	9.77	6.72	2.1	24.97	9.48	7.35	2.04	23.73
		20	11.13	4.46	2.39	31.23	11.08	5.22	2.38	31.01	11.03	5.96	2.37	30.76	10.93	6.69	2.35	30.29	10.66	7.33	2.29	29
	5	15	5.45	4.53	0.93	6.13	5.6	5.36	0.96	6.49	6.04	6.04	1.04	7.48	6.73	6.73	1.16	9.04	7.43	7.43	1.27	10.67
		17	7.39	4.41	1.27	10.57	7.36	5.17	1.26	10.5	7.3	5.9	1.25	10.35	7.13	6.59	1.22	9.95	7.49	7.49	1.29	10.83
		19	9.5	4.3	1.63	16.2	9.45	5.05	1.62	16.06	9.41	5.8	1.61	15.92	9.29	6.51	1.59	15.58	8.96	7.12	1.54	14.65
		20	10.61	4.23	1.82	19.54	10.57	4.99	1.81	19.41	10.52	5.74	1.81	19.25	10.43	6.47	1.79	18.99	10.14	7.1	1.74	18.1
	6	15	4.95	4.31	0.71	2.67	5.28	5.22	0.75	3.3	5.8	5.8	0.83	4.51	6.5	6.5	0.93	6.06	7.2	7.2	1.03	7.37
		17	6.84	4.17	0.98	6.71	6.82	4.93	0.97	6.66	6.77	5.68	0.97	6.58	6.78	6.44	0.97	6.59	7.24	7.24	1.04	7.45
		19	8.96	4.07	1.28	10.72	8.92	4.82	1.28	10.63	8.87	5.57	1.27	10.54	8.77	6.28	1.25	10.33	8.46	6.91	1.21	9.73
		20	10.07	4	1.44	13.06	10.03	4.76	1.43	12.97	9.98	5.51	1.43	12.86	9.91	6.24	1.42	12.71	9.68	6.9	1.38	12.21
7	3	15	5	4.33	1.43	12.84	5.17	5.17	1.48	13.63	5.79	5.79	1.66	16.49	6.48	6.48	1.86	20.03	7.18	7.18	2.06	23.83
		17	6.91	4.2	1.98	22.35	6.88	4.96	1.97	22.18	6.84	5.7	1.96	21.93	6.67	6.39	1.91	21.02	7.18	7.18	2.06	23.85
		19	9.02	4.09	2.59	35.3	8.97	4.84	2.57	34.97	8.92	5.59	2.56	34.66	8.82	6.31	2.53	33.97	8.45	6.9	2.42	31.56
		20	10.12	4.02	2.9	43.09	10.08	4.78	2.89	42.78	10.03	5.52	2.88	42.41	9.95	6.26	2.86	41.87	9.63	6.88	2.76	39.58
	4	15	4.52	4.11	0.97	6.58	4.9	4.9	1.05	7.6	5.56	5.56	1.19	9.41	6.26	6.26	1.34	11.5	6.95	6.95	1.49	13.74
		17	6.37	3.97	1.37	11.86	6.36	4.73	1.36	11.8	6.32	5.48	1.36	11.69	6.38	6.26	1.37	11.87	6.95	6.95	1.49	13.75
		19	8.49	3.86	1.82	19.31	8.44	4.61	1.81	19.11	8.39	5.36	1.8	18.95	8.31	6.09	1.78	18.63	8	6.72	1.72	17.46
		20	9.58	3.79	2.06	23.78	9.54	4.55	2.05	23.62	9.5	5.3	2.04	23.4	9.43	6.04	2.03	23.13	9.17	6.69	1.97	22.07
	5	15	4.14	3.96	0.71	2.86	4.65	4.65	0.8	4.22	5.33	5.33	0.91	5.88	6.03	6.03	1.04	7.36	6.72	6.72	1.15	8.87
		17	5.8	3.73	1	6.89	5.8	4.5	1	6.88	5.84	5.28	1	6.96	6.1	6.1	1.05	7.52	6.73	6.73	1.16	8.87
		19	7.93	3.63	1.36	11.72	7.88	4.38	1.35	11.59	7.85	5.13	1.35	11.51	7.52	6.3	1.37	20.1	7.52	6.52	1.29	10.72
		20	9.03	3.56	1.55	14.62	8.99	4.32	1.55	14.51	8.95	5.07	1.54	14.38	8.89	5.81	1.53	14.23	8.69	6.49	1.49	13.68
	6	15	3.82	3.82	0.55	1.63	4.4	4.4	0.63	2	5.09	5.09	0.73	3.18	5.8	5.8	0.83	4.73	6.49	6.49	0.93	6.06
		17	5.18	3.47	0.74	3.4	5.22	4.26	0.75	3.49	5.45	5.12	0.78	4	5.86	5.86	0.84	4.86	6.5	6.5	0.93	6.06
		19	7.35	3.39	1.05	7.53	7.3	4.14	1.04	7.44	7.27	4.9	1.04	7.39	7.22	5.64	1.03	7.31	7.07	6.33	1.01	7.04
		20	8.46	3.33	1.21	9.55	8.42	4.09	1.21	9.48	8.37	4.84	1.2	9.39	8.33	5.59	1.19	9.31	8.15	6.27	1.17	8.98
9	3	15	3.73	3.73	1.07	7.7	4.37	4.37	1.25	10.06	5.07	5.07	1.45	12.97	5.77	5.77	1.66	16.17	6.47	6.47	1.86	19.65
		17	5.31	3.53	1.52	14.01	5.32	4.3	1.52	14.03	5.35	5.08	1.53	14.21	5.78	5.78	1.66	16.19	6.47	6.47	1.86	19.66
		19	7.42	3.42	2.13	24.86	7.37	4.17	2.11	24.56	7.34	4.93	2.1	24.37	7.29	5.67	2.09	24.09	7.04	6.32	2.02	22.67
		20	8.52	3.35	2.44	31.51	8.48	4.11	2.43	31.26	8.43	4.86	2.42	30.95	8.38	5.61	2.41	30.67	8.21	6.3	2.36	29.59
	4	15	3.46	3.46	0.74	3.55	4.14	4.14	0.89	5.56	4.84	4.84	1.04	7.34	5.55	5.55	1.19	9.23	6.24	6.24	1.34	11.28
		17	4.71	3.29	1.01	6.99	4.75	4.07	1.02	7.1	5.01	4.94	1.08	7.77	5.55	5.55	1.19	9.23	6.25	6.25	1.34	11.28
		19	6.85	3.19	1.47	13.19	6.8	3.94	1.46	13.02	6.77	4.7	1.46	12.94	6.74	5.45	1.45	12.82	6.62	6.15	1.42	12.44
		20	7.95	3.13	1.71	17.01	7.91	3.88	1.7	16.86	7.86	4.64	1.69	16.69	7.83	5.39	1.68	16.56	7.69	6.09	1.65	16.05
	5	15	3.2	3.2	0.55	1.57	3.9	3.9	0.67	2.53	4.61	4.61	0.79	4.33	5.32	5.32	0.91	5.84	6.02	6.02	1.03	7.23
		17	4.09	3.04	0.7	3	4.29	3.89	0.74	3.54	4.72	4.72	0.81	4.58	5.32	5.32	0.91	5.84	6.02	6.02	1.03	7.24
		19	6.23	2.95	1.07	7.67	6.19	3.7	1.06	7.57	6.18	4.47	1.06	7.57	6.17	5.22	1.06	7.53	6.27	6.02	1.08	7.76
		20	7.36	2.89	1.27	10.16	7.31	3.65	1.26	10.05	7.27	4.41	1.25	9.95	7.25	5.16	1.25	9.89	7.14	5.87	1.23	9.64
	6	15	2.94	2.94	0.42	1.18	3.66	3.66	0.52	1.48	4.38	4.38	0.63	2.06	5.09	5.09	0.73	3.43	5.79	5.79	0.83	4.82
		17	3.5	2.81	0.5	1.4	3.92	3.74	0.56	1.6	4.44	4.44	0.64	2.17	5.09	5.09	0.73	3.43	5.79	5.79	0.83	4.83
		19	5.56	2.69	0.8	4.41	5.52	3.45	0.79	4.34	5.56	4.23	0.8	4.4	5.68	5.04	0.81	4.63	5.98	5.9	0.86	5.15
		20	6.72	2.65	0.96	6.37	6.67	3.4	0.96	6.28	6.64	4.17	0.95	6.24	6.64	4.93	0.95	6.23	6.6	5.67	0.95	6.16

(Continued)

		(none)																					
EWT	ΔT	Indoor temp (W.B.)	Indoor temperature (D.B.)																				
			21				23				25				27				29				
°C	°C	°C	TC	SC	WF	WPD	TC	SC	WF	WPD	TC	SC	WF	WPD	TC	SC	WF	WPD	TC	SC	WF	WPD	
			kW	kW	m ³ /h	kPa	kW	kW	m ³ /h	kPa	kW	kW	m ³ /h	kPa	kW	kW	m ³ /h	kPa	kW	kW	m ³ /h	kPa	
11	3	15	2.94	2.94	0.84	4.99	3.65	3.65	1.05	7.31	4.36	4.36	1.25	9.87	5.06	5.06	1.45	12.73	5.76	5.76	1.65	15.87	
		17	3.6	2.85	1.03	7.12	3.83	3.71	1.1	7.92	4.36	4.36	1.25	9.88	5.07	5.07	1.45	12.74	5.77	5.77	1.65	15.88	
		19	5.71	2.74	1.64	15.6	5.66	3.5	1.62	15.39	5.66	4.27	1.62	15.4	5.65	5.02	1.62	15.32	5.85	5.85	1.68	16.3	
		20	6.83	2.69	1.96	21.22	6.77	3.44	1.94	20.92	6.73	4.2	1.93	20.72	6.71	4.96	1.93	20.6	6.64	5.68	1.9	20.21	
	4	15	2.7	2.7	0.58	1.68	3.42	3.42	0.73	3.64	4.13	4.13	0.89	5.5	4.84	4.84	1.04	7.2	5.54	5.54	1.19	9.06	
		17	3.06	2.65	0.66	2.55	3.52	3.52	0.76	3.94	4.13	4.13	0.89	5.5	4.84	4.84	1.04	7.21	5.54	5.54	1.19	9.06	
		19	5.05	2.5	1.09	7.73	5.02	3.26	1.08	7.66	5.06	4.04	1.09	7.77	5.19	4.85	1.12	8.11	5.59	5.59	1.2	9.19	
		20	6.21	2.46	1.34	10.98	6.15	3.21	1.32	10.79	6.12	3.97	1.32	10.73	6.12	4.74	1.32	10.73	6.1	5.48	1.31	10.65	
	5	15	2.45	2.45	0.42	1.14	3.18	3.18	0.55	1.51	3.9	3.9	0.67	2.75	4.61	4.61	0.79	4.41	5.31	5.31	0.91	5.75	
		17	2.66	2.5	0.46	1.23	3.23	3.23	0.56	1.55	3.9	3.9	0.67	2.75	4.61	4.61	0.79	4.41	5.31	5.31	0.91	5.76	
		19	4.37	2.24	0.75	3.91	4.37	3.02	0.75	3.92	4.49	3.83	0.77	4.17	4.84	4.72	0.83	4.87	5.34	5.34	0.92	5.81	
		20	5.53	2.21	0.95	6.16	5.48	2.97	0.94	6.06	5.47	3.73	0.94	6.04	5.51	4.51	0.95	6.11	5.69	5.33	0.98	6.46	
	6	15	2.19	2.19	0.31	0.83	2.93	2.93	0.42	1.12	3.66	3.66	0.52	1.41	4.37	4.37	0.63	2.22	5.08	5.08	0.73	3.61	
		17	2.31	2.31	0.33	0.88	2.96	2.96	0.42	1.13	3.66	3.66	0.52	1.41	4.37	4.37	0.63	2.22	5.08	5.08	0.73	3.61	
		19	3.66	2	0.52	1.4	3.69	2.78	0.53	1.42	4.05	3.67	0.58	1.74	4.53	4.53	0.65	2.51	5.1	5.1	0.73	3.64	
		20	4.81	1.96	0.69	3.11	4.75	2.71	0.68	2.98	4.76	3.48	0.68	3	4.99	4.32	0.72	3.45	5.34	5.21	0.77	4.09	
	13	3	15	2.21	2.21	0.63	2.35	2.93	2.93	0.84	4.94	3.64	3.64	1.05	7.17	4.35	4.35	1.25	9.69	5.05	5.05	1.45	12.5
			17	2.27	2.27	0.65	2.6	2.93	2.93	0.84	4.95	3.65	3.65	1.05	7.18	4.35	4.35	1.25	9.7	5.06	5.06	1.45	12.51
			19	3.85	2.06	1.1	7.85	3.85	2.83	1.1	7.86	3.98	3.65	1.14	8.32	4.4	4.4	1.26	9.87	5.06	5.06	1.45	12.51
			20	4.99	2.02	1.43	12.22	4.92	2.77	1.41	11.92	4.93	3.54	1.41	11.95	4.97	4.32	1.43	12.15	5.19	5.15	1.49	13.06
4		15	1.96	1.96	0.42	1.09	2.69	2.69	0.58	1.75	3.41	3.41	0.73	3.76	4.12	4.12	0.89	5.41	4.83	4.83	1.04	7.07	
		17	1.99	1.99	0.43	1.11	2.69	2.69	0.58	1.75	3.41	3.41	0.73	3.77	4.13	4.13	0.89	5.41	4.83	4.83	1.04	7.08	
		19	3.19	1.83	0.69	3.14	3.21	2.61	0.69	3.22	3.6	3.51	0.78	4.23	4.15	4.15	0.89	5.46	4.83	4.83	1.04	7.08	
		20	4.32	1.78	0.94	5.94	4.24	2.53	0.91	5.67	4.25	3.3	0.91	5.69	4.49	4.15	0.97	6.25	4.91	4.91	1.06	7.26	
5		15	-	-	-	-	2.45	2.45	0.42	1.08	3.18	3.18	0.55	1.5	3.89	3.89	0.67	2.95	4.6	4.6	0.79	4.41	
		17	-	-	-	-	2.45	2.45	0.42	1.08	3.18	3.18	0.55	1.5	3.89	3.89	0.67	2.95	4.6	4.6	0.79	4.41	
		19	-	-	-	-	2.74	2.45	0.47	1.2	3.29	3.29	0.57	1.66	3.9	3.9	0.67	2.98	4.6	4.6	0.79	4.41	
		20	-	-	-	-	3.52	2.28	0.61	2.13	3.69	3.11	0.63	2.48	4.12	4.02	0.71	3.48	4.65	4.65	0.8	4.49	
6		15	-	-	-	-	2.19	2.19	0.31	0.79	2.93	2.93	0.42	1.06	3.65	3.65	0.52	1.38	4.37	4.37	0.63	2.4	
		17	-	-	-	-	2.19	2.19	0.31	0.79	2.93	2.93	0.42	1.06	3.66	3.66	0.52	1.38	4.37	4.37	0.63	2.4	
		19	-	-	-	-	2.36	2.32	0.34	0.85	3	3	0.43	1.08	3.66	3.66	0.53	1.39	4.37	4.37	0.63	2.4	
		20	-	-	-	-	2.81	2.05	0.4	1.01	3.25	2.96	0.47	1.17	3.8	3.8	0.55	1.52	4.39	4.39	0.63	2.45	
15		3	15	-	-	-	-	2.21	2.21	0.63	2.55	2.93	2.93	0.84	4.87	3.64	3.64	1.05	7.05	4.34	4.34	1.25	9.52
			17	-	-	-	-	2.21	2.21	0.63	2.55	2.93	2.93	0.84	4.87	3.64	3.64	1.05	7.05	4.35	4.35	1.25	9.52
			19	-	-	-	-	2.32	2.31	0.67	3	2.93	2.93	0.84	4.88	3.64	3.64	1.05	7.05	4.35	4.35	1.25	9.53
			20	-	-	-	-	3	2.11	0.86	5.09	3.18	2.94	0.91	5.59	3.68	3.68	1.06	7.19	4.35	4.35	1.25	9.53
	4	15	-	-	-	-	1.96	1.96	0.42	1.04	2.69	2.69	0.58	1.89	3.41	3.41	0.73	3.8	4.12	4.12	0.89	5.32	
		17	-	-	-	-	1.96	1.96	0.42	1.04	2.69	2.69	0.58	1.89	3.41	3.41	0.73	3.8	4.12	4.12	0.89	5.32	
		19	-	-	-	-	2.02	2.02	0.43	1.07	2.69	2.69	0.58	1.89	3.41	3.41	0.73	3.8	4.12	4.12	0.89	5.33	
		20	-	-	-	-	2.36	1.9	0.51	1.28	2.83	2.83	0.61	2.26	3.43	3.43	0.74	3.84	4.12	4.12	0.89	5.33	
	5	15	-	-	-	-	-	-	-	-	2.45	2.45	0.42	1.02	3.17	3.17	0.55	1.57	3.89	3.89	0.67	3.08	
		17	-	-	-	-	-	-	-	-	2.45	2.45	0.42	1.02	3.17	3.17	0.55	1.57	3.89	3.89	0.67	3.08	
		19	-	-	-	-	-	-	-	-	2.45	2.45	0.42	1.02	3.17	3.17	0.55	1.57	3.89	3.89	0.67	3.08	
		20	-	-	-	-	-	-	-	-	2.52	2.52	0.43	1.05	3.18	3.18	0.55	1.59	3.89	3.89	0.67	3.09	
	6	15	-	-	-	-	-	-	-	-	2.19	2.19	0.31	0.75	2.93	2.93	0.42	1.01	3.65	3.65	0.52	1.41	
		17	-	-	-	-	-	-	-	-	2.19	2.19	0.31	0.75	2.93	2.93	0.42	1.01	3.65	3.65	0.52	1.41	
		19	-	-	-	-	-	-	-	-	2.19	2.19	0.31	0.75	2.93	2.93	0.42	1.01	3.65	3.65	0.52	1.41	
		20	-	-	-	-	-	-	-	-	2.23	2.23	0.32	0.76	2.93	2.93	0.42	1.01	3.65	3.65	0.52	1.41	

Abbreviations:

EWT: Enter Water Temp. (°C) Δt: Temperature Difference (°C) DB: Dry Bulb Temp. (°C) WF: Water Flow (m³/h)
 WB: Wet Bulb Temp. (°C) TC: Total Cooling Capacity (kW) SC: Sensible Cooling Capacity (kW) WPD: Water Pressure Drop (kPa)

(none)

EWT	ΔT	Indoor temp (W.B.)	Indoor temperature (D.B.)																				
			21				23				25				27				29				
			TC	SC	WF	WPD	TC	SC	WF	WPD	TC	SC	WF	WPD	TC	SC	WF	WPD	TC	SC	WF	WPD	
°C	°C	°C	kW	kW	m ³ /h	kPa	kW	kW	m ³ /h	kPa	kW	kW	m ³ /h	kPa	kW	kW	m ³ /h	kPa	kW	kW	m ³ /h	kPa	
5	3	15	6.72	5.2	1.92	21.62	6.68	5.98	1.91	21.39	6.78	6.78	1.94	21.97	7.49	7.49	2.14	26.06	8.21	8.21	2.35	30.5	
		17	8.74	5.07	2.5	33.97	8.7	5.86	2.49	33.68	8.61	6.62	2.47	33.12	8.3	7.26	2.38	31.04	8.39	8.09	2.4	31.63	
		19	10.93	4.94	3.14	50.03	10.88	5.73	3.12	49.6	10.82	6.5	3.1	49.16	10.64	7.22	3.05	47.72	10.38	7.89	2.98	45.76	
		20	12.09	4.87	3.47	59.57	12.03	5.66	3.45	59.14	11.98	6.44	3.44	58.65	11.86	7.18	3.4	57.68	11.61	7.86	3.33	55.55	
	4	15	6.2	4.96	1.33	11.5	6.2	5.76	1.33	11.51	6.53	6.53	1.4	12.58	7.25	7.25	1.56	15.02	7.97	7.97	1.71	17.65	
		17	8.21	4.83	1.76	18.56	8.18	5.62	1.75	18.42	8.11	6.39	1.74	18.15	7.84	7.05	1.68	17.13	8.07	7.95	1.73	18.03	
		19	10.41	4.7	2.23	27.82	10.35	5.49	2.22	27.58	10.3	6.27	2.21	27.35	10.15	7	2.18	26.67	9.85	7.65	2.11	25.3	
		20	11.56	4.63	2.48	33.32	11.51	5.42	2.47	33.09	11.45	6.2	2.46	32.82	11.36	6.96	2.44	32.34	11.08	7.63	2.38	30.99	
	5	15	5.65	4.71	0.97	6.61	5.82	5.59	1	7	6.29	6.29	1.08	8.03	7.01	7.01	1.2	9.68	7.73	7.73	1.33	11.43	
		17	7.67	4.59	1.32	11.26	7.64	5.38	1.31	11.18	7.58	6.15	1.3	11.05	7.41	6.87	1.27	10.62	7.8	7.8	1.34	11.58	
		19	9.86	4.47	1.69	17.26	9.81	5.25	1.68	17.11	9.77	6.03	1.68	16.97	9.65	6.77	1.66	16.61	9.3	7.42	1.6	15.62	
		20	11.01	4.39	1.89	20.83	10.97	5.19	1.88	20.69	10.92	5.96	1.87	20.52	10.83	6.73	1.86	20.26	10.54	7.4	1.81	19.34	
	6	15	5.14	4.48	0.73	3.02	5.49	5.44	0.78	3.78	6.04	6.04	0.86	5.07	6.77	6.77	0.97	6.58	7.5	7.5	1.07	7.92	
		17	7.09	4.34	1.01	7.18	7.07	5.13	1.01	7.14	7.03	5.91	1.01	7.06	7.07	6.72	1.01	7.13	7.53	7.53	1.08	7.99	
		19	9.3	4.22	1.33	11.42	9.25	5	1.32	11.31	9.21	5.79	1.32	11.22	9.12	6.55	1.3	11.03	8.82	7.21	1.26	10.44	
		20	10.45	4.15	1.5	13.91	10.41	4.94	1.49	13.82	10.36	5.72	1.48	13.7	10.29	6.49	1.47	13.55	10.05	7.19	1.44	13.02	
	7	3	15	5.18	4.5	1.48	13.67	5.38	5.38	1.54	14.58	6.03	6.03	1.73	17.67	6.75	6.75	1.93	21.48	7.48	7.48	2.14	25.56
			17	7.18	4.37	2.06	23.82	7.15	5.16	2.05	23.65	7.1	5.94	2.03	23.39	6.96	6.67	1.99	22.61	7.48	7.48	2.14	25.58
			19	9.36	4.25	2.69	37.67	9.31	5.03	2.67	37.31	9.26	5.81	2.66	36.98	9.16	6.57	2.63	36.28	8.78	7.19	2.52	33.7
			20	10.5	4.17	3.02	45.99	10.46	4.96	3	45.67	10.41	5.74	2.99	45.26	10.33	6.51	2.97	44.7	10.02	7.17	2.87	42.36
4		15	4.69	4.29	1.01	7.03	5.1	5.1	1.09	8.14	5.79	5.79	1.24	10.08	6.52	6.52	1.4	12.32	7.24	7.24	1.55	14.73	
		17	6.61	4.13	1.42	12.62	6.59	4.93	1.42	12.56	6.56	5.71	1.41	12.45	6.65	6.54	1.43	12.72	7.24	7.24	1.56	14.74	
		19	8.81	4.01	1.89	20.58	8.76	4.79	1.88	20.37	8.71	5.58	1.87	20.2	8.64	6.34	1.86	19.9	8.31	7	1.78	18.63	
		20	9.95	3.93	2.14	25.35	9.91	4.73	2.13	25.18	9.86	5.51	2.12	24.95	9.8	6.28	2.1	24.69	9.54	6.97	2.05	23.58	
5		15	4.3	4.13	0.74	3.28	4.84	4.84	0.83	4.72	5.55	5.55	0.95	6.36	6.28	6.28	1.08	7.89	7	7	1.2	9.5	
		17	6.02	3.88	1.03	7.33	6.02	4.68	1.03	7.33	6.06	5.5	1.04	7.43	6.35	6.35	1.09	8.05	7.01	7.01	1.2	9.51	
		19	8.23	3.77	1.41	12.48	8.18	4.55	1.4	12.34	8.14	5.34	1.4	12.25	7.84	6.63	1.43	22	7.81	6.79	1.34	11.42	
		20	9.37	3.69	1.61	15.57	9.33	4.49	1.6	15.45	9.28	5.27	1.59	15.31	9.23	6.05	1.59	15.17	9.03	6.76	1.55	14.6	
6		15	3.97	3.97	0.57	1.69	4.57	4.57	0.65	2.22	5.3	5.3	0.76	3.65	6.04	6.04	0.86	5.22	6.76	6.76	0.97	6.53	
		17	5.36	3.61	0.77	3.82	5.41	4.43	0.77	3.92	5.66	5.33	0.81	4.46	6.09	6.09	0.87	5.33	6.77	6.77	0.97	6.53	
		19	7.62	3.52	1.09	8.01	7.57	4.3	1.08	7.91	7.54	5.1	1.08	7.87	7.5	5.87	1.07	7.79	7.37	6.61	1.06	7.57	
		20	8.77	3.45	1.26	10.17	8.73	4.25	1.25	10.09	8.68	5.03	1.24	9.99	8.64	5.81	1.24	9.91	8.49	6.54	1.22	9.62	
9		3	15	3.88	3.88	1.11	8.22	4.55	4.55	1.3	10.78	5.28	5.28	1.51	13.9	6.02	6.02	1.72	17.34	6.74	6.74	1.93	21.07
			17	5.51	3.67	1.58	14.91	5.51	4.48	1.58	14.94	5.56	5.29	1.59	15.18	6.02	6.02	1.72	17.35	6.74	6.74	1.93	21.09
			19	7.7	3.55	2.21	26.5	7.65	4.34	2.19	26.17	7.61	5.13	2.18	25.97	7.57	5.9	2.17	25.69	7.34	6.6	2.1	24.38
			20	8.84	3.48	2.54	33.6	8.8	4.27	2.53	33.33	8.75	5.06	2.51	33	8.7	5.84	2.5	32.7	8.53	6.56	2.45	31.61
	4	15	3.6	3.6	0.77	4.01	4.31	4.31	0.93	5.99	5.05	5.05	1.08	7.86	5.78	5.78	1.24	9.89	6.51	6.51	1.4	12.09	
		17	4.88	3.42	1.05	7.42	4.93	4.24	1.06	7.55	5.21	5.15	1.12	8.3	5.78	5.78	1.24	9.89	6.51	6.51	1.4	12.09	
		19	7.11	3.31	1.53	14.04	7.05	4.1	1.52	13.85	7.03	4.89	1.51	13.77	6.99	5.67	1.5	13.65	6.9	6.43	1.48	13.36	
		20	8.25	3.24	1.77	18.12	8.21	4.04	1.76	17.95	8.16	4.82	1.75	17.77	8.12	5.61	1.75	17.63	8	6.35	1.72	17.19	
	5	15	3.33	3.33	0.57	1.66	4.06	4.06	0.7	2.92	4.8	4.8	0.83	4.77	5.54	5.54	0.95	6.27	6.27	6.27	1.08	7.75	
		17	4.24	3.16	0.73	3.41	4.46	4.05	0.77	3.96	4.91	4.91	0.84	5	5.54	5.54	0.95	6.28	6.27	6.27	1.08	7.75	
		19	6.46	3.06	1.11	8.15	6.42	3.85	1.1	8.05	6.41	4.65	1.1	8.04	6.4	5.44	1.1	8.01	6.52	6.28	1.12	8.28	
		20	7.64	3	1.31	10.81	7.58	3.79	1.3	10.68	7.54	4.58	1.3	10.59	7.52	5.37	1.29	10.53	7.43	6.13	1.28	10.32	
	6	15	3.06	3.06	0.44	1.23	3.81	3.81	0.55	1.55	4.56	4.56	0.65	2.35	5.3	5.3	0.76	3.87	6.03	6.03	0.86	5.24	
		17	3.63	2.93	0.52	1.46	4.07	3.9	0.58	1.72	4.62	4.62	0.66	2.48	5.3	5.3	0.76	3.88	6.03	6.03	0.86	5.24	
		19	5.77	2.79	0.83	4.81	5.72	3.58	0.82	4.7	5.76	4.4	0.82	4.77	5.9	5.25	0.85	5.01	6.22	6.16	0.89	5.55	
		20	6.97	2.75	1	6.77	6.91	3.53	0.99	6.67	6.89	4.33	0.99	6.63	6.88	5.13	0.99	6.63	6.85	5.91	0.98	6.58	

(Continued)

		(none)																				
EWT	ΔT	Indoor temp (W.B.)	Indoor temperature (D.B.)																			
			21				23				25				27				29			
			TC	SC	WF	WPD	TC	SC	WF	WPD	TC	SC	WF	WPD	TC	SC	WF	WPD	TC	SC	WF	WPD
°C	°C	°C	kW	kW	m ³ /h	kPa	kW	kW	m ³ /h	kPa	kW	kW	m ³ /h	kPa	kW	kW	m ³ /h	kPa	kW	kW	m ³ /h	kPa
11	3	15	3.06	3.06	0.88	5.38	3.8	3.8	1.09	7.83	4.54	4.54	1.3	10.58	5.28	5.28	1.51	13.65	6	6	1.72	17.03
		17	3.74	2.97	1.07	7.59	3.98	3.87	1.14	8.45	4.54	4.54	1.3	10.58	5.28	5.28	1.51	13.65	6.01	6.01	1.72	17.03
		19	5.92	2.85	1.7	16.5	5.87	3.64	1.68	16.37	5.87	4.44	1.68	16.39	5.86	5.23	1.68	16.33	6.09	6.09	1.75	17.43
		20	7.08	2.79	2.03	22.6	7.02	3.58	2.02	22.28	6.98	4.37	2	22.06	6.96	5.16	2	21.95	6.89	5.92	1.98	21.55
	4	15	2.81	2.81	0.6	1.87	3.56	3.56	0.77	4.06	4.3	4.3	0.92	5.9	5.04	5.04	1.08	7.72	5.77	5.77	1.24	9.7
		17	3.18	2.76	0.68	2.9	3.65	3.65	0.79	4.33	4.3	4.3	0.93	5.9	5.04	5.04	1.08	7.72	5.77	5.77	1.24	9.71
		19	5.25	2.6	1.13	8.27	5.2	3.39	1.12	8.12	5.24	4.21	1.13	8.25	5.39	5.06	1.16	8.65	5.81	5.81	1.25	9.83
		20	6.43	2.55	1.38	11.6	6.37	3.34	1.37	11.47	6.35	4.13	1.37	11.41	6.35	4.93	1.37	11.41	6.33	5.72	1.36	11.36
	5	15	2.55	2.55	0.44	1.18	3.31	3.31	0.57	1.62	4.06	4.06	0.7	3.15	4.8	4.8	0.83	4.79	5.53	5.53	0.95	6.17
		17	2.76	2.6	0.47	1.27	3.36	3.36	0.58	1.69	4.06	4.06	0.7	3.15	4.8	4.8	0.83	4.79	5.53	5.53	0.95	6.17
		19	4.52	2.33	0.78	4.23	4.53	3.14	0.78	4.25	4.66	3.99	0.8	4.51	5.03	4.92	0.87	5.23	5.56	5.56	0.96	6.22
		20	5.75	2.3	0.99	6.57	5.67	3.08	0.98	6.42	5.66	3.88	0.97	6.41	5.71	4.7	0.98	6.5	5.91	5.56	1.02	6.9
	6	15	2.27	2.27	0.33	0.87	3.05	3.05	0.44	1.16	3.81	3.81	0.55	1.5	4.55	4.55	0.65	2.56	5.29	5.29	0.76	4
		17	2.4	2.4	0.34	0.91	3.08	3.08	0.44	1.17	3.81	3.81	0.55	1.5	4.55	4.55	0.65	2.56	5.29	5.29	0.76	4
		19	3.8	2.07	0.54	1.49	3.83	2.89	0.55	1.51	4.2	3.83	0.6	1.95	4.71	4.71	0.67	2.87	5.31	5.31	0.76	4.03
		20	4.99	2.03	0.72	3.45	4.91	2.81	0.7	3.31	4.93	3.62	0.71	3.33	5.18	4.51	0.74	3.8	5.55	5.43	0.8	4.45
13	3	15	2.3	2.3	0.66	2.72	3.05	3.05	0.88	5.31	3.8	3.8	1.09	7.68	4.53	4.53	1.3	10.39	5.27	5.27	1.51	13.41
		17	2.36	2.36	0.68	2.98	3.05	3.05	0.88	5.31	3.8	3.8	1.09	7.69	4.53	4.53	1.3	10.39	5.27	5.27	1.51	13.41
		19	3.98	2.14	1.14	8.32	3.99	2.95	1.14	8.34	4.13	3.8	1.18	8.86	4.58	4.58	1.31	10.55	5.27	5.27	1.51	13.42
		20	5.18	2.1	1.49	13.0	5.08	2.87	1.46	12.62	5.1	3.68	1.46	12.69	5.15	4.5	1.48	12.92	5.4	5.38	1.55	13.97
	4	15	2.04	2.04	0.44	1.14	2.8	2.8	0.6	2.01	3.55	3.55	0.76	4.12	4.3	4.3	0.92	5.8	5.03	5.03	1.08	7.58
		17	2.07	2.07	0.45	1.15	2.81	2.81	0.6	2.01	3.56	3.56	0.77	4.12	4.3	4.3	0.92	5.8	5.03	5.03	1.08	7.58
		19	3.3	1.9	0.71	3.46	3.33	2.72	0.72	3.55	3.74	3.66	0.8	4.55	4.32	4.32	0.93	5.85	5.03	5.03	1.08	7.58
		20	4.45	1.84	0.96	6.15	4.39	2.63	0.94	6	4.4	3.44	0.95	6.04	4.66	4.33	1	6.66	5.1	5.1	1.1	7.77
	5	15	-	-	-	-	2.55	2.55	0.44	1.12	3.31	3.31	0.57	1.68	4.05	4.05	0.7	3.32	4.79	4.79	0.83	4.75
		17	-	-	-	-	2.55	2.55	0.44	1.12	3.31	3.31	0.57	1.68	4.05	4.05	0.7	3.32	4.79	4.79	0.83	4.75
		19	-	-	-	-	2.86	2.56	0.49	1.26	3.42	3.42	0.59	1.88	4.06	4.06	0.7	3.34	4.79	4.79	0.83	4.75
		20	-	-	-	-	3.65	2.38	0.63	2.41	3.82	3.24	0.66	2.8	4.28	4.19	0.74	3.81	4.84	4.84	0.83	4.83
	6	15	-	-	-	-	2.28	2.28	0.33	0.82	3.05	3.05	0.44	1.1	3.8	3.8	0.55	1.52	4.55	4.55	0.65	2.75
		17	-	-	-	-	2.28	2.28	0.33	0.82	3.05	3.05	0.44	1.1	3.81	3.81	0.55	1.52	4.55	4.55	0.65	2.75
		19	-	-	-	-	2.45	2.42	0.35	0.88	3.12	3.12	0.45	1.13	3.81	3.81	0.55	1.52	4.55	4.55	0.65	2.75
		20	-	-	-	-	2.91	2.13	0.42	1.04	3.38	3.09	0.48	1.22	3.96	3.96	0.57	1.71	4.57	4.57	0.66	2.8
15	3	15	-	-	-	-	2.3	2.3	0.66	2.9	3.05	3.05	0.88	5.22	3.79	3.79	1.09	7.55	4.53	4.53	1.3	10.21
		17	-	-	-	-	2.3	2.3	0.66	2.91	3.05	3.05	0.88	5.22	3.79	3.79	1.09	7.55	4.53	4.53	1.3	10.21
		19	-	-	-	-	2.41	2.41	0.69	3.33	3.05	3.05	0.88	5.23	3.79	3.79	1.09	7.56	4.53	4.53	1.3	10.22
		20	-	-	-	-	3.12	2.2	0.9	5.43	3.29	3.06	0.95	5.95	3.83	3.83	1.1	7.69	4.53	4.53	1.3	10.22
	4	15	-	-	-	-	2.04	2.04	0.44	1.08	2.8	2.8	0.6	2.19	3.55	3.55	0.76	4.11	4.29	4.29	0.92	5.7
		17	-	-	-	-	2.04	2.04	0.44	1.08	2.8	2.8	0.6	2.19	3.55	3.55	0.76	4.11	4.29	4.29	0.92	5.7
		19	-	-	-	-	2.1	2.1	0.45	1.11	2.8	2.8	0.6	2.19	3.55	3.55	0.77	4.11	4.29	4.29	0.92	5.71
		20	-	-	-	-	2.44	1.98	0.53	1.39	2.93	2.93	0.63	2.57	3.57	3.57	0.77	4.15	4.29	4.29	0.92	5.71
	5	15	-	-	-	-	-	-	-	-	2.55	2.55	0.44	1.06	3.3	3.3	0.57	1.81	4.05	4.05	0.7	3.4
		17	-	-	-	-	-	-	-	-	2.55	2.55	0.44	1.07	3.3	3.3	0.57	1.81	4.05	4.05	0.7	3.4
		19	-	-	-	-	-	-	-	-	2.55	2.55	0.44	1.07	3.31	3.31	0.57	1.81	4.05	4.05	0.7	3.41
		20	-	-	-	-	-	-	-	-	2.62	2.62	0.45	1.09	3.31	3.31	0.57	1.83	4.05	4.05	0.7	3.41
	6	15	-	-	-	-	-	-	-	-	2.28	2.28	0.33	0.78	3.05	3.05	0.44	1.05	3.8	3.8	0.55	1.6
		17	-	-	-	-	-	-	-	-	2.28	2.28	0.33	0.78	3.05	3.05	0.44	1.05	3.8	3.8	0.55	1.6
		19	-	-	-	-	-	-	-	-	2.28	2.28	0.33	0.78	3.05	3.05	0.44	1.05	3.8	3.8	0.55	1.6
		20	-	-	-	-	-	-	-	-	2.32	2.32	0.33	0.79	3.05	3.05	0.44	1.05	3.8	3.8	0.55	1.6

Abbreviations:

EWT: Enter Water Temp. (°C) Δt: Temperature Difference (°C) DB: Dry Bulb Temp. (°C) WF: Water Flow (m³/h)
 WB: Wet Bulb Temp. (°C) TC: Total Cooling Capacity (kW) SC: Sensible Cooling Capacity (kW) WPD: Water Pressure Drop (kPa)

MUCS-24-W7

EWT	ΔT	Indoor temp (W.B.)	Indoor temperature (D.B.)																			
			21				23				25				27				29			
			TC	SC	WF	WPD	TC	SC	WF	WPD	TC	SC	WF	WPD	TC	SC	WF	WPD	TC	SC	WF	WPD
°C	°C	°C	kW	kW	m ³ /h	kPa	kW	kW	m ³ /h	kPa	kW	kW	m ³ /h	kPa	kW	kW	m ³ /h	kPa	kW	kW	m ³ /h	kPa
5	3	15	6.75	5.23	1.93	21.82	6.72	6.02	1.92	21.62	6.84	6.84	1.96	22.32	7.55	7.55	2.16	26.4	8.27	8.27	2.37	30.91
		17	8.79	5.1	2.52	34.29	8.75	5.89	2.51	34.01	8.68	6.67	2.49	33.56	8.39	7.34	2.4	31.65	8.43	8.15	2.41	31.92
		19	10.9	4.97	3.15	50.52	10.94	5.76	3.14	50.1	10.89	6.55	3.12	49.68	10.73	7.28	3.08	48.47	10.44	7.95	2.99	46.21
		20	12.1	4.89	3.49	60.15	12.1	5.69	3.47	59.74	12.05	6.48	3.46	59.25	11.95	7.24	3.43	58.41	11.7	7.93	3.36	56.33
	4	15	6.23	4.99	1.34	11.6	6.24	5.81	1.34	11.63	6.59	6.59	1.41	12.77	7.31	7.31	1.57	15.21	8.03	8.03	1.72	17.88
		17	8.26	4.86	1.77	18.73	8.22	5.66	1.76	18.59	8.17	6.44	1.75	18.38	7.95	7.14	1.7	17.54	8.12	8.01	1.74	18.21
		19	10.4	4.73	2.25	28.09	10.41	5.52	2.24	27.85	10.36	6.31	2.22	27.62	10.25	7.06	2.2	27.1	9.91	7.71	2.13	25.58
		20	11.6	4.65	2.49	33.63	11.57	5.46	2.49	33.41	11.52	6.24	2.47	33.14	11.44	7.01	2.46	32.74	11.17	7.7	2.4	31.45
	5	15	5.68	4.74	0.97	6.67	5.86	5.63	1	7.08	6.33	6.33	1.09	8.13	7.06	7.06	1.21	9.81	7.79	7.79	1.34	11.58
		17	7.71	4.61	1.32	11.35	7.68	5.41	1.32	11.27	7.64	6.2	1.31	11.18	7.49	6.93	1.28	10.81	7.85	7.85	1.35	11.71
		19	9.92	4.49	1.7	17.42	9.87	5.28	1.69	17.27	9.82	6.07	1.69	17.13	9.72	6.83	1.67	16.84	9.41	7.49	1.61	15.92
		20	11.0	4.41	1.9	21.02	11.03	5.22	1.89	20.89	10.98	6	1.88	20.71	10.91	6.78	1.87	20.5	10.67	7.47	1.83	19.72
6	15	5.16	4.52	0.74	3.07	5.52	5.48	0.79	3.87	6.09	6.09	0.87	5.19	6.82	6.82	0.98	6.68	7.55	7.55	1.08	8.02	
	17	7.13	4.36	1.02	7.24	7.11	5.16	1.02	7.2	7.08	5.96	1.01	7.15	7.14	6.79	1.02	7.27	7.58	7.58	1.08	8.08	
	19	9.35	4.24	1.34	11.52	9.3	5.03	1.33	11.41	9.26	5.83	1.32	11.32	9.18	6.6	1.31	11.17	8.92	7.28	1.28	10.63	
	20	10.5	4.17	1.5	14.03	10.47	4.97	1.5	13.94	10.41	5.76	1.49	13.83	10.36	6.54	1.48	13.69	10.16	7.26	1.45	13.25	
7	3	15	5.21	4.54	1.49	13.78	5.42	5.42	1.55	14.75	6.07	6.07	1.74	17.89	6.8	6.8	1.95	21.75	7.53	7.53	2.16	25.9
		17	7.21	4.4	2.07	24.03	7.18	5.2	2.06	23.86	7.14	5.99	2.05	23.64	7.06	6.75	2.02	23.16	7.54	7.54	2.16	25.92
		19	9.41	4.27	2.7	38.03	9.36	5.06	2.69	37.66	9.32	5.85	2.67	37.34	9.24	6.63	2.65	36.84	8.89	7.27	2.55	34.43
		20	10.5	4.19	3.03	46.42	10.52	4.99	3.02	46.11	10.47	5.78	3	45.7	10.41	6.56	2.99	45.25	10.14	7.25	2.91	43.28
	4	15	4.71	4.32	1.01	7.09	5.13	5.13	1.1	8.23	5.83	5.83	1.25	10.2	6.56	6.56	1.41	12.47	7.29	7.29	1.57	14.92
		17	6.64	4.15	1.43	12.73	6.63	4.96	1.42	12.67	6.6	5.75	1.42	12.58	6.73	6.6	1.44	12.99	7.3	7.3	1.57	14.93
		19	8.86	4.03	1.9	20.77	8.8	4.82	1.89	20.55	8.76	5.62	1.88	20.38	8.7	6.4	1.87	20.15	8.44	7.08	1.81	19.12
		20	10	3.95	2.15	25.58	9.96	4.76	2.14	25.41	9.91	5.54	2.13	25.18	9.86	6.33	2.12	24.95	9.66	7.05	2.08	24.12
	5	15	4.33	4.16	0.74	3.35	4.87	4.87	0.84	4.81	5.58	5.58	0.96	6.44	6.32	6.32	1.09	7.99	7.06	7.06	1.21	9.62
		17	6.04	3.9	1.04	7.38	6.04	4.71	1.04	7.39	6.1	5.54	1.05	7.51	6.42	6.42	1.1	8.19	7.06	7.06	1.21	9.63
		19	8.27	3.79	1.42	12.59	8.22	4.58	1.41	12.45	8.18	5.38	1.41	12.35	7.87	6.68	1.44	22.3	7.9	6.86	1.36	11.64
		20	9.42	3.71	1.62	15.7	9.38	4.52	1.61	15.59	9.33	5.31	1.6	15.45	9.28	6.09	1.6	15.32	9.12	6.83	1.57	14.86
6	15	3.99	3.99	0.57	1.71	4.61	4.61	0.66	2.27	5.34	5.34	0.76	3.73	6.08	6.08	0.87	5.3	6.81	6.81	0.98	6.61	
	17	5.38	3.63	0.77	3.85	5.44	4.46	0.78	3.97	5.7	5.38	0.82	4.54	6.16	6.16	0.88	5.45	6.82	6.82	0.98	6.62	
	19	7.66	3.54	1.1	8.08	7.6	4.33	1.09	7.98	7.58	5.13	1.08	7.93	7.55	5.92	1.08	7.87	7.45	6.68	1.07	7.71	
	20	8.82	3.47	1.26	10.25	8.78	4.27	1.26	10.17	8.73	5.06	1.25	10.08	8.69	5.85	1.24	10	8.57	6.61	1.23	9.77	
9	3	15	3.9	3.9	1.12	8.3	4.58	4.58	1.31	10.91	5.32	5.32	1.53	14.08	6.06	6.06	1.74	17.56	6.79	6.79	1.95	21.35
		17	5.53	3.69	1.58	15.01	5.54	4.51	1.59	15.06	5.6	5.34	1.61	15.35	6.06	6.06	1.74	17.57	6.8	6.8	1.95	21.37
		19	7.75	3.57	2.22	26.75	7.69	4.36	2.21	26.41	7.65	5.16	2.2	26.2	7.61	5.95	2.18	25.95	7.45	6.68	2.14	25.02
		20	8.89	3.5	2.55	33.91	8.85	4.3	2.54	33.65	8.79	5.09	2.52	33.3	8.75	5.88	2.51	33.02	8.64	6.63	2.48	32.29
	4	15	3.62	3.62	0.78	4.08	4.34	4.34	0.93	6.06	5.08	5.08	1.09	7.95	5.82	5.82	1.25	10.01	6.55	6.55	1.41	12.24
		17	4.89	3.43	1.05	7.45	4.95	4.27	1.06	7.61	5.25	5.19	1.13	8.39	5.82	5.82	1.25	10.01	6.56	6.56	1.41	12.25
		19	7.14	3.33	1.54	14.16	7.08	4.12	1.52	13.97	7.06	4.92	1.52	13.89	7.03	5.72	1.51	13.79	6.98	6.49	1.5	13.61
		20	8.29	3.26	1.78	18.28	8.25	4.06	1.77	18.11	8.2	4.85	1.76	17.93	8.16	5.65	1.76	17.79	8.08	6.41	1.74	17.47
	5	15	3.35	3.35	0.58	1.67	4.09	4.09	0.7	2.99	4.84	4.84	0.83	4.85	5.58	5.58	0.96	6.35	6.32	6.32	1.09	7.85
		17	4.25	3.18	0.73	3.44	4.48	4.08	0.77	4.02	4.94	4.94	0.85	5.07	5.58	5.58	0.96	6.36	6.32	6.32	1.09	7.85
		19	6.49	3.07	1.12	8.2	6.44	3.87	1.11	8.1	6.44	4.68	1.11	8.1	6.43	5.48	1.11	8.09	6.59	6.34	1.13	8.44
		20	7.67	3.02	1.32	10.9	7.62	3.81	1.31	10.77	7.58	4.61	1.3	10.67	7.55	5.41	1.3	10.62	7.48	6.18	1.29	10.44
6	15	3.08	3.08	0.44	1.24	3.84	3.84	0.55	1.56	4.59	4.59	0.66	2.41	5.33	5.33	0.76	3.95	6.07	6.07	0.87	5.31	
	17	3.65	2.95	0.52	1.46	4.09	3.93	0.59	1.73	4.65	4.65	0.67	2.54	5.34	5.34	0.76	3.96	6.08	6.08	0.87	5.32	
	19	5.8	2.81	0.83	4.84	5.73	3.6	0.82	4.73	5.78	4.43	0.83	4.8	5.93	5.29	0.85	5.07	6.28	6.22	0.9	5.66	
	20	6.99	2.75	1	6.81	6.94	3.55	0.99	6.72	6.91	4.36	0.99	6.68	6.91	5.17	0.99	6.68	6.91	5.96	0.99	6.68	

(Continued)

MUCS-24-W7																							
EWT	ΔT	Indo or temp (W.B.)	Indoor temperature (D.B.)																				
			21				23				25				27				29				
			TC	SC	WF	WPD	TC	SC	WF	WPD	TC	SC	WF	WPD	TC	SC	WF	WPD	TC	SC	WF	WPD	
°C	°C	°C	kW	kW	m³/h	kPa	kW	kW	m³/h	kPa	kW	kW	m³/h	kPa	kW	kW	m³/h	kPa	kW	kW	m³/h	kPa	
11	3	15	3.08	3.08	0.88	5.45	3.83	3.83	1.1	7.92	4.57	4.57	1.31	10.71	5.32	5.32	1.52	13.82	6.05	6.05	1.74	17.25	
		17	3.75	2.99	1.07	7.63	4	3.89	1.15	8.52	4.58	4.58	1.31	10.71	5.32	5.32	1.52	13.83	6.05	6.05	1.74	17.26	
		19	5.94	2.86	1.7	16.7	5.89	3.66	1.69	16.48	5.9	4.47	1.69	16.51	5.9	5.28	1.69	16.5	6.13	6.13	1.76	17.65	
		20	7.12	2.81	2.04	22.8	7.06	3.6	2.03	22.47	7.02	4.4	2.01	22.24	7	5.2	2.01	22.15	6.94	5.97	1.99	21.81	
	4	15	2.83	2.83	0.61	1.91	3.58	3.58	0.77	4.13	4.33	4.33	0.93	5.97	5.08	5.08	1.09	7.81	5.81	5.81	1.25	9.83	
		17	3.19	2.78	0.69	2.94	3.68	3.68	0.79	4.38	4.33	4.33	0.93	5.97	5.08	5.08	1.09	7.81	5.81	5.81	1.25	9.83	
		19	5.26	2.61	1.13	8.29	5.21	3.41	1.12	8.16	5.26	4.24	1.13	8.3	5.43	5.1	1.17	8.74	5.86	5.86	1.26	9.95	
		20	6.46	2.56	1.39	11.7	6.39	3.35	1.38	11.55	6.37	4.16	1.37	11.49	6.38	4.97	1.37	11.51	6.38	5.76	1.37	11.5	
	5	15	2.56	2.56	0.44	1.19	3.33	3.33	0.57	1.65	4.09	4.09	0.7	3.22	4.83	4.83	0.83	4.86	5.57	5.57	0.96	6.25	
		17	2.78	2.62	0.48	1.29	3.38	3.38	0.58	1.71	4.09	4.09	0.7	3.23	4.83	4.83	0.83	4.86	5.57	5.57	0.96	6.25	
		19	4.55	2.35	0.78	4.29	4.55	3.16	0.78	4.29	4.67	4.02	0.8	4.55	5.06	4.96	0.87	5.28	5.6	5.6	0.96	6.3	
		20	5.76	2.31	0.99	6.61	5.68	3.09	0.98	6.44	5.68	3.91	0.98	6.44	5.73	4.73	0.99	6.55	5.95	5.61	1.02	6.98	
6	15	2.29	2.29	0.33	0.87	3.07	3.07	0.44	1.17	3.83	3.83	0.55	1.52	4.59	4.59	0.66	2.62	5.33	5.33	0.76	4.07		
	17	2.4	2.4	0.34	0.91	3.1	3.1	0.44	1.18	3.83	3.83	0.55	1.52	4.59	4.59	0.66	2.62	5.33	5.33	0.76	4.07		
	19	3.82	2.09	0.55	1.51	3.84	2.91	0.55	1.53	4.22	3.86	0.61	1.98	4.74	4.74	0.68	2.93	5.34	5.34	0.77	4.1		
	20	5.01	2.04	0.72	3.5	4.95	2.83	0.71	3.38	4.95	3.65	0.71	3.37	5.2	4.54	0.75	3.85	5.59	5.48	0.8	4.51		
13	3	15	2.32	2.32	0.66	2.78	3.07	3.07	0.88	5.37	3.82	3.82	1.1	7.78	4.57	4.57	1.31	10.52	5.31	5.31	1.52	13.58	
		17	2.38	2.38	0.68	3.04	3.07	3.07	0.88	5.37	3.82	3.82	1.1	7.78	4.57	4.57	1.31	10.52	5.31	5.31	1.52	13.59	
		19	4	2.15	1.15	8.39	4	2.97	1.15	8.39	4.15	3.83	1.19	8.92	4.61	4.61	1.32	10.68	5.31	5.31	1.52	13.59	
		20	5.19	2.1	1.49	13.0	5.12	2.89	1.47	12.75	5.11	3.7	1.47	12.74	5.18	4.53	1.49	13.01	5.44	5.42	1.56	14.15	
	4	15	2.06	2.06	0.44	1.15	2.82	2.82	0.61	2.06	3.58	3.58	0.77	4.18	4.33	4.33	0.93	5.87	5.07	5.07	1.09	7.67	
		17	2.08	2.08	0.45	1.16	2.82	2.82	0.61	2.06	3.58	3.58	0.77	4.18	4.33	4.33	0.93	5.88	5.07	5.07	1.09	7.68	
		19	3.32	1.92	0.71	3.52	3.36	2.74	0.72	3.62	3.76	3.69	0.81	4.59	4.35	4.35	0.94	5.92	5.07	5.07	1.09	7.68	
		20	6.6	2.61	0.98	6.36	4.41	2.65	0.95	6.07	4.41	3.46	0.95	6.06	4.69	4.36	1.01	6.72	5.14	5.14	1.11	7.86	
	5	15	-	-	-	-	2.56	2.56	0.44	1.13	3.33	3.33	0.57	1.72	4.08	4.08	0.7	3.38	4.83	4.83	0.83	4.81	
		17	-	-	-	-	2.57	2.57	0.44	1.13	3.33	3.33	0.57	1.72	4.08	4.08	0.7	3.39	4.83	4.83	0.83	4.81	
		19	-	-	-	-	2.87	2.57	0.49	1.26	3.44	3.44	0.59	1.92	4.09	4.09	0.7	3.41	4.83	4.83	0.83	4.82	
		20	-	-	-	-	3.68	2.4	0.63	2.47	3.83	3.26	0.66	2.83	4.31	4.23	0.74	3.86	4.87	4.87	0.84	4.89	
6	15	-	-	-	-	2.29	2.29	0.33	0.83	3.07	3.07	0.44	1.11	3.83	3.83	0.55	1.55	4.58	4.58	0.66	2.81		
	17	-	-	-	-	2.29	2.29	0.33	0.83	3.07	3.07	0.44	1.11	3.83	3.83	0.55	1.55	4.58	4.58	0.66	2.81		
	19	-	-	-	-	2.47	2.44	0.35	0.89	3.13	3.13	0.45	1.13	3.83	3.83	0.55	1.55	4.59	4.59	0.66	2.82		
	20	-	-	-	-	2.92	2.14	0.42	1.05	3.4	3.11	0.49	1.23	3.98	3.98	0.57	1.74	4.61	4.61	0.66	2.86		
15	3	15	-	-	-	-	2.31	2.31	0.66	2.97	3.07	3.07	0.88	5.28	3.82	3.82	1.1	7.65	4.56	4.56	1.31	10.34	
		17	-	-	-	-	2.31	2.31	0.66	2.97	3.07	3.07	0.88	5.29	3.82	3.82	1.1	7.65	4.56	4.56	1.31	10.34	
		19	-	-	-	-	2.43	2.42	0.7	3.39	3.07	3.07	0.88	5.29	3.82	3.82	1.1	7.65	4.56	4.56	1.31	10.35	
		20	-	-	-	-	3.14	2.22	0.9	5.5	3.31	3.09	0.95	6	3.86	3.86	1.11	7.78	4.56	4.56	1.31	10.35	
	4	15	-	-	-	-	2.06	2.06	0.44	1.09	2.82	2.82	0.61	2.24	3.58	3.58	0.77	4.16	4.32	4.32	0.93	5.77	
		17	-	-	-	-	2.06	2.06	0.44	1.09	2.82	2.82	0.61	2.25	3.58	3.58	0.77	4.16	4.32	4.32	0.93	5.78	
		19	-	-	-	-	2.11	2.11	0.45	1.12	2.82	2.82	0.61	2.25	3.58	3.58	0.77	4.17	4.32	4.32	0.93	5.78	
		20	-	-	-	-	2.46	2	0.53	1.42	2.95	2.95	0.63	2.61	3.59	3.59	0.77	4.2	4.32	4.32	0.93	5.78	
	5	15	-	-	-	-	-	-	-	-	2.56	2.56	0.44	1.07	3.33	3.33	0.57	1.86	4.08	4.08	0.7	3.46	
		17	-	-	-	-	-	-	-	-	2.56	2.56	0.44	1.07	3.33	3.33	0.57	1.86	4.08	4.08	0.7	3.46	
		19	-	-	-	-	-	-	-	-	2.57	2.57	0.44	1.07	3.33	3.33	0.57	1.86	4.08	4.08	0.7	3.46	
		20	-	-	-	-	-	-	-	-	2.63	2.63	0.45	1.1	3.34	3.34	0.57	1.87	4.08	4.08	0.7	3.46	
6	15	-	-	-	-	-	-	-	-	2.29	2.29	0.33	0.79	3.07	3.07	0.44	1.06	3.83	3.83	0.55	1.64		
	17	-	-	-	-	-	-	-	-	2.29	2.29	0.33	0.79	3.07	3.07	0.44	1.06	3.83	3.83	0.55	1.64		
	19	-	-	-	-	-	-	-	-	2.29	2.29	0.33	0.79	3.07	3.07	0.44	1.06	3.83	3.83	0.55	1.64		
	20	-	-	-	-	-	-	-	-	2.33	2.33	0.33	0.8	3.07	3.07	0.44	1.06	3.83	3.83	0.55	1.64		

Abbreviations:

EWT: Enter Water Temp. (°C) Δt: Temperature Difference (°C) DB: Dry Bulb Temp. (°C) WF: Water Flow (m³/h)
 WB: Wet Bulb Temp. (°C) TC: Total Cooling Capacity (kW) SC: Sensible Cooling Capacity (kW) WPD: Water Pressure Drop (kPa)

MUCS-36-W7

EWT	ΔT	Indoor temp (W.B.)	Indoor temperature (D.B.)																				
			21				23				25				27				29				
			TC	SC	WF	WPD	TC	SC	WF	WPD	TC	SC	WF	WPD	TC	SC	WF	WPD	TC	SC	WF	WPD	
°C	°C	°C	kW	kW	m ³ /h	kPa	kW	kW	m ³ /h	kPa	kW	kW	m ³ /h	kPa	kW	kW	m ³ /h	kPa	kW	kW	m ³ /h	kPa	
5	3	15	9.34	7.14	2.67	19.83	9.19	8.14	2.63	19.29	9.3	9.25	2.66	19.7	10.23	10.23	2.93	23.17	11.19	11.19	3.2	27.05	
		17	12.14	7	3.48	31.08	12.05	8.04	3.45	30.71	11.7	8.95	3.35	29.16	11.54	9.94	3.3	28.48	11.7	11.06	3.35	29.16	
		19	15.16	6.86	4.35	45.62	15.08	7.91	4.32	45.21	14.94	8.92	4.28	44.48	14.63	9.85	4.19	42.9	14.52	10.86	4.16	42.33	
		20	16.76	6.77	4.81	54.3	16.67	7.83	4.78	53.82	16.58	8.87	4.76	53.26	16.37	9.85	4.7	52.11	16.09	10.78	4.61	50.57	
	4	15	8.64	6.81	1.85	10.61	8.54	7.84	1.83	10.42	8.95	8.95	1.92	11.28	9.91	9.91	2.13	13.39	10.88	10.88	2.33	15.69	
		17	11.43	6.68	2.45	17.07	11.36	7.72	2.44	16.89	11.1	8.68	2.38	16.23	10.8	9.6	2.32	15.5	11.19	10.83	2.4	16.47	
		19	14.46	6.54	3.1	25.48	14.38	7.59	3.09	25.25	14.27	8.61	3.06	24.91	13.92	9.53	2.99	23.89	13.76	10.52	2.95	23.41	
		20	16.05	6.46	3.45	30.5	15.97	7.52	3.43	30.24	15.88	8.55	3.41	29.94	15.66	9.53	3.36	29.24	15.33	10.45	3.29	28.19	
	5	15	7.91	6.48	1.36	5.93	8.03	7.61	1.38	6.16	8.62	8.62	1.48	7.13	9.59	9.59	1.65	8.64	10.56	10.56	1.81	10.19	
		17	10.7	6.34	1.84	10.4	10.64	7.4	1.83	10.31	10.44	8.38	1.79	9.97	10.2	9.34	1.75	9.6	10.77	10.64	1.85	10.53	
		19	13.73	6.21	2.36	15.87	13.66	7.26	2.34	15.73	13.56	8.3	2.33	15.54	13.21	9.21	2.27	14.86	12.98	10.17	2.23	14.43	
		20	15.32	6.13	2.63	19.14	15.25	7.19	2.62	18.98	15.17	8.23	2.6	18.8	14.95	9.21	2.57	18.34	14.57	10.11	2.5	17.56	
	6	15	7.18	6.15	1.03	2.52	7.57	7.41	1.08	2.96	8.28	8.28	1.18	4.02	9.27	9.27	1.33	5.61	10.24	10.24	1.47	6.99	
		17	9.93	6	1.42	6.56	9.88	7.06	1.41	6.5	9.71	8.06	1.39	6.27	9.71	9.12	1.39	6.26	10.39	10.39	1.49	7.18	
		19	12.97	5.88	1.86	10.54	12.9	6.93	1.85	10.44	12.82	7.97	1.83	10.33	12.53	8.92	1.79	9.94	12.17	9.82	1.74	9.46	
		20	14.57	5.79	2.08	12.82	14.5	6.86	2.07	12.72	14.42	7.91	2.06	12.61	14.24	8.9	2.04	12.34	13.79	9.77	1.97	11.69	
	7	3	15	7.23	6.18	2.07	12.62	7.41	7.33	2.12	13.15	8.24	8.24	2.36	15.76	9.22	9.22	2.64	19.1	10.19	10.19	2.92	22.67
			17	9.99	6.03	2.86	21.9	9.94	7.09	2.85	21.7	9.77	8.09	2.8	21.08	9.5	9.03	2.72	20.07	10.21	10.21	2.92	22.73
			19	13.01	5.89	3.73	34.47	12.93	6.94	3.71	34.13	12.84	7.98	3.68	33.73	12.46	8.89	3.57	32	12.2	9.83	3.5	30.87
			20	14.6	5.81	4.19	42.07	14.52	6.87	4.17	41.71	14.44	7.92	4.14	41.3	14.2	8.89	4.07	40.13	13.78	9.77	3.95	38.09
4		15	6.53	5.88	1.4	6.43	7.02	7.02	1.51	7.32	7.92	7.92	1.7	9.01	8.9	8.9	1.91	10.99	9.88	9.88	2.12	13.11	
		17	9.24	5.7	1.98	11.69	9.2	6.77	1.97	11.6	9.06	7.78	1.95	11.32	9.07	8.84	1.95	11.33	9.89	9.89	2.12	13.12	
		19	12.26	5.57	2.63	18.91	12.19	6.62	2.62	18.73	12.11	7.67	2.6	18.53	11.83	8.62	2.54	17.79	11.42	9.5	2.45	16.75	
		20	13.85	5.49	2.97	23.29	13.78	6.55	2.96	23.1	13.7	7.6	2.94	22.88	13.51	8.59	2.9	22.36	13.02	9.45	2.8	20.96	
5		15	5.98	5.64	1.03	2.62	6.65	6.65	1.14	3.79	7.6	7.6	1.3	5.52	8.59	8.59	1.47	7.03	9.56	9.56	1.64	8.47	
		17	8.44	5.36	1.45	6.81	8.42	6.44	1.45	6.78	8.39	7.49	1.44	6.74	8.69	8.68	1.49	7.18	9.57	9.57	1.64	8.47	
		19	11.48	5.24	1.97	11.52	11.41	6.3	1.96	11.41	11.35	7.35	1.95	11.3	11.19	9.04	1.96	36.6	10.64	9.18	1.83	10.14	
		20	13.07	5.16	2.25	14.36	13	6.23	2.23	14.24	12.93	7.28	2.22	14.11	12.79	8.29	2.2	13.84	12.25	9.13	2.11	12.87	
6		15	5.51	5.44	0.79	1.63	6.29	6.29	0.9	1.91	7.27	7.27	1.04	2.79	8.26	8.26	1.18	4.29	9.25	9.25	1.32	5.7	
		17	7.57	5.01	1.08	3.26	7.59	6.1	1.09	3.28	7.83	7.26	1.12	3.63	8.33	8.33	1.19	4.4	9.25	9.25	1.32	5.71	
		19	10.66	4.9	1.53	7.42	10.59	5.96	1.52	7.34	10.54	7.02	1.51	7.28	10.36	8.01	1.48	7.06	10.03	8.94	1.44	6.68	
		20	12.25	4.82	1.75	9.41	12.19	5.89	1.75	9.33	12.13	6.95	1.74	9.25	12.01	7.97	1.72	9.1	11.56	8.85	1.66	8.53	
9		3	15	5.36	5.36	1.54	7.48	6.23	6.23	1.78	9.65	7.23	7.23	2.07	12.41	8.21	8.21	2.35	15.43	9.19	9.19	2.64	18.7
			17	7.71	5.06	2.21	13.85	7.7	6.14	2.21	13.81	7.68	7.2	2.2	13.76	8.22	8.22	2.36	15.44	9.2	9.2	2.64	18.72
			19	10.72	4.93	3.08	24.35	10.65	5.98	3.06	24.08	10.6	7.04	3.04	23.85	10.42	8.03	2.99	23.16	9.86	8.86	2.83	21.06
			20	12.3	4.84	3.53	30.85	12.24	5.91	3.51	30.57	12.17	6.96	3.49	30.27	12.04	7.98	3.46	29.75	11.45	8.81	3.28	27.25
	4	15	4.97	4.97	1.07	3.19	5.9	5.9	1.27	5.25	6.91	6.91	1.48	7.03	7.9	7.9	1.7	8.82	8.88	8.88	1.91	10.76	
		17	6.88	4.73	1.48	6.98	6.91	5.82	1.48	7.02	7.19	7	1.54	7.51	7.9	7.9	1.7	8.83	8.88	8.88	1.91	10.77	
		19	9.92	4.6	2.13	12.97	9.85	5.66	2.12	12.83	9.81	6.72	2.11	12.73	9.67	7.73	2.08	12.42	9.29	8.64	2	11.62	
		20	11.51	4.52	2.47	16.71	11.44	5.59	2.46	16.55	11.38	6.65	2.45	16.39	11.28	7.68	2.42	16.15	10.84	8.56	2.33	15.08	
	5	15	4.59	4.59	0.79	1.57	5.57	5.57	0.96	2.23	6.58	6.58	1.13	3.94	7.58	7.58	1.3	5.54	8.56	8.56	1.47	6.9	
		17	5.98	4.37	1.03	2.87	6.22	5.54	1.07	3.3	6.76	6.76	1.16	4.26	7.58	7.58	1.3	5.54	8.57	8.57	1.47	6.91	
		19	9.06	4.26	1.56	7.59	9	5.32	1.55	7.51	8.98	6.39	1.54	7.48	8.88	7.42	1.53	7.34	8.84	8.46	1.52	7.28	
		20	10.67	4.19	1.83	10.01	10.6	5.26	1.82	9.91	10.55	6.32	1.81	9.82	10.48	7.36	1.8	9.71	10.12	8.28	1.74	9.16	
	6	15	4.22	4.22	0.61	1.18	5.24	5.24	0.75	1.47	6.25	6.25	0.9	1.88	7.25	7.25	1.04	3.02	8.24	8.24	1.18	4.46	
		17	5.11	4.03	0.73	1.42	5.67	5.32	0.81	1.59	6.37	6.37	0.91	1.98	7.26	7.26	1.04	3.03	8.25	8.25	1.18	4.47	
		19	8.11	3.89	1.16	4.29	8.08	4.97	1.16	4.26	8.1	6.05	1.16	4.28	8.17	7.14	1.17	4.37	8.45	8.31	1.21	4.75	
		20	9.78	3.85	1.4	6.3	9.71	4.91	1.39	6.22	9.67	5.98	1.39	6.18	9.62	7.03	1.38	6.13	9.37	8	1.34	5.85	

(Continued)

MUCS-36-W7																						
EWT	ΔT	Indoor temp (W.B.)	Indoor temperature (D.B.)																			
			21				23				25				27				29			
			TC	SC	WF	WPD	TC	SC	WF	WPD	TC	SC	WF	WPD	TC	SC	WF	WPD	TC	SC	WF	WPD
°C	°C	°C	kW	kW	m ³ /h	kPa	kW	kW	m ³ /h	kPa	kW	kW	m ³ /h	kPa	kW	kW	m ³ /h	kPa	kW	kW	m ³ /h	kPa
11	3	15	4.19	4.19	1.2	4.72	5.21	5.21	1.49	7.01	6.21	6.21	1.78	9.45	7.21	7.21	2.07	12.15	8.19	8.19	2.35	15.12
		17	5.25	4.08	1.51	7.11	5.53	5.27	1.58	7.75	6.22	6.22	1.78	9.47	7.21	7.21	2.07	12.16	8.19	8.19	2.35	15.13
		19	8.28	3.96	2.38	15.4	8.22	5.02	2.36	15.21	8.21	6.1	2.35	15.17	8.12	7.13	2.33	14.91	8.23	8.23	2.36	15.24
		20	9.88	3.89	2.83	20.82	9.8	4.95	2.81	20.56	9.75	6.01	2.8	20.38	9.69	7.06	2.78	20.16	9.4	8.01	2.7	19.13
	4	15	3.86	3.86	0.83	1.6	4.88	4.88	1.05	3.27	5.89	5.89	1.27	5.24	6.89	6.89	1.48	6.89	7.88	7.88	1.69	8.64
		17	4.45	3.78	0.96	2.37	5.06	5.06	1.09	3.67	5.89	5.89	1.27	5.24	6.89	6.89	1.48	6.89	7.88	7.88	1.69	8.65
		19	7.36	3.61	1.58	7.7	7.34	4.69	1.58	7.66	7.37	5.78	1.58	7.71	7.46	6.87	1.6	7.87	7.89	7.89	1.7	8.67
		20	9.01	3.56	1.94	10.85	8.93	4.62	1.92	10.69	8.9	5.69	1.91	10.63	8.86	6.75	1.91	10.55	8.67	7.73	1.86	10.16
	5	15	3.51	3.51	0.6	1.13	4.55	4.55	0.78	1.48	5.56	5.56	0.96	2.41	6.57	6.57	1.13	4.09	7.56	7.56	1.3	5.48
		17	3.85	3.56	0.66	1.24	4.65	4.65	0.8	1.52	5.56	5.56	0.96	2.41	6.57	6.57	1.13	4.1	7.56	7.56	1.3	5.48
		19	6.4	3.25	1.1	3.85	6.37	4.33	1.1	3.8	6.53	5.46	1.12	4.04	6.94	6.68	1.19	4.66	7.56	7.56	1.3	5.49
		20	8.06	3.21	1.39	6.11	7.98	4.27	1.37	6.02	7.99	5.36	1.38	6.04	7.99	6.42	1.38	6.04	8.11	7.53	1.4	6.19
6	15	3.14	3.14	0.45	0.83	4.2	4.2	0.6	1.11	5.23	5.23	0.75	1.39	6.24	6.24	0.89	1.95	7.24	7.24	1.04	3.24	
	17	3.34	3.34	0.48	0.88	4.26	4.26	0.61	1.13	5.23	5.23	0.75	1.39	6.24	6.24	0.89	1.96	7.24	7.24	1.04	3.24	
	19	5.34	2.88	0.77	1.41	5.37	3.97	0.77	1.43	5.87	5.23	0.84	1.66	6.5	6.5	0.93	2.25	7.25	7.25	1.04	3.26	
	20	7.01	2.83	1.01	2.95	6.97	3.91	1	2.9	6.99	5	1	2.92	7.22	6.15	1.04	3.23	7.63	7.35	1.09	3.78	
13	3	15	3.16	3.16	0.91	2.06	4.18	4.18	1.2	4.71	5.19	5.19	1.49	6.87	6.19	6.19	1.78	9.26	7.18	7.18	2.06	11.91
		17	3.26	3.26	0.93	2.31	4.19	4.19	1.2	4.72	5.2	5.2	1.49	6.88	6.2	6.2	1.78	9.26	7.19	7.19	2.06	11.92
		19	5.6	2.97	1.61	7.79	5.6	4.06	1.61	7.81	5.77	5.19	1.66	8.21	6.28	6.28	1.8	9.48	7.19	7.19	2.06	11.93
		20	7.24	2.92	2.08	12.06	7.16	3.98	2.06	11.84	7.19	5.07	2.06	11.92	7.2	6.14	2.07	11.95	7.4	7.27	2.12	12.52
	4	15	2.81	2.81	0.61	1.09	3.85	3.85	0.83	1.59	4.87	4.87	1.05	3.45	5.88	5.88	1.26	5.17	6.87	6.87	1.48	6.75
		17	2.86	2.86	0.62	1.11	3.85	3.85	0.83	1.59	4.87	4.87	1.05	3.45	5.88	5.88	1.26	5.17	6.87	6.87	1.48	6.76
		19	4.62	2.63	0.99	2.95	4.67	3.72	1.01	3.06	5.2	4.99	1.12	4.08	5.92	5.92	1.27	5.24	6.87	6.87	1.48	6.76
		20	6.25	2.57	1.35	5.75	6.2	3.64	1.33	5.66	6.24	4.73	1.34	5.72	6.48	5.89	1.39	6.11	7	7	1.51	6.97
	5	15	-	-	-	-	3.5	3.5	0.6	1.07	4.54	4.54	0.78	1.42	5.55	5.55	0.96	2.6	6.55	6.55	1.13	4.15
		17	-	-	-	-	3.51	3.51	0.6	1.07	4.54	4.54	0.78	1.42	5.55	5.55	0.96	2.61	6.55	6.55	1.13	4.15
		19	-	-	-	-	3.97	3.48	0.68	1.21	4.74	4.74	0.82	1.55	5.58	5.58	0.96	2.65	6.56	6.56	1.13	4.15
		20	-	-	-	-	5.17	3.29	0.89	2.05	5.37	4.43	0.92	2.34	5.94	5.7	1.02	3.26	6.63	6.63	1.14	4.25
6	15	-	-	-	-	3.14	3.14	0.45	0.79	4.19	4.19	0.6	1.06	5.22	5.22	0.75	1.33	6.22	6.22	0.89	2.09	
	17	-	-	-	-	3.14	3.14	0.45	0.79	4.19	4.19	0.6	1.06	5.22	5.22	0.75	1.33	6.23	6.23	0.89	2.09	
	19	-	-	-	-	3.43	3.3	0.49	0.86	4.32	4.32	0.62	1.09	5.23	5.23	0.75	1.34	6.23	6.23	0.89	2.1	
	20	-	-	-	-	4.09	2.92	0.59	1.02	4.73	4.22	0.68	1.19	5.48	5.48	0.79	1.44	6.28	6.28	0.9	2.16	
15	3	15	-	-	-	-	3.15	3.15	0.91	2.24	4.17	4.17	1.2	4.66	5.18	5.18	1.49	6.74	6.18	6.18	1.77	9.08
		17	-	-	-	-	3.15	3.15	0.91	2.24	4.17	4.17	1.2	4.66	5.18	5.18	1.49	6.74	6.18	6.18	1.77	9.08
		19	-	-	-	-	3.34	3.27	0.96	2.74	4.19	4.19	1.2	4.69	5.18	5.18	1.49	6.75	6.18	6.18	1.78	9.09
		20	-	-	-	-	4.38	3.02	1.26	5.09	4.61	4.18	1.32	5.53	5.28	5.28	1.52	6.95	6.18	6.18	1.78	9.09
	4	15	-	-	-	-	2.81	2.81	0.6	1.03	3.84	3.84	0.83	1.66	4.86	4.86	1.05	3.55	5.86	5.86	1.26	5.08
		17	-	-	-	-	2.81	2.81	0.61	1.03	3.84	3.84	0.83	1.66	4.86	4.86	1.05	3.55	5.86	5.86	1.26	5.08
		19	-	-	-	-	2.89	2.89	0.62	1.06	3.85	3.85	0.83	1.66	4.86	4.86	1.05	3.55	5.86	5.86	1.26	5.09
		20	-	-	-	-	3.42	2.71	0.74	1.27	4.09	4	0.88	2.07	4.91	4.91	1.06	3.63	5.87	5.87	1.26	5.09
	5	15	-	-	-	-	-	-	-	-	3.5	3.5	0.6	1.02	4.53	4.53	0.78	1.42	5.54	5.54	0.95	2.77
		17	-	-	-	-	-	-	-	-	3.5	3.5	0.6	1.02	4.53	4.53	0.78	1.42	5.54	5.54	0.95	2.77
		19	-	-	-	-	-	-	-	-	3.5	3.5	0.6	1.02	4.53	4.53	0.78	1.42	5.54	5.54	0.96	2.78
		20	-	-	-	-	-	-	-	-	3.64	3.64	0.63	1.06	4.55	4.55	0.78	1.44	5.54	5.54	0.96	2.78
6	15	-	-	-	-	-	-	-	-	3.13	3.13	0.45	0.75	4.18	4.18	0.6	1	5.21	5.21	0.75	1.3	
	17	-	-	-	-	-	-	-	-	3.13	3.13	0.45	0.75	4.18	4.18	0.6	1	5.21	5.21	0.75	1.3	
	19	-	-	-	-	-	-	-	-	3.14	3.14	0.45	0.75	4.19	4.19	0.6	1	5.21	5.21	0.75	1.3	
	20	-	-	-	-	-	-	-	-	3.21	3.21	0.46	0.77	4.2	4.2	0.6	1.01	5.21	5.21	0.75	1.3	

Abbreviations:

EWT: Enter Water Temp. (°C) Δt: Temperature Difference (°C) DB: Dry Bulb Temp. (°C) WF: Water Flow (m³/h)
 WB: Wet Bulb Temp. (°C) TC: Total Cooling Capacity (kW) SC: Sensible Cooling Capacity (kW) WPD: Water Pressure Drop (kPa)

Heating Capacity Table

(none)													
EWT	ΔT	Indoor temperature (D.B.)											
		16			18			20			22		
		TH	WF	WPD	TH	WF	WPD	TH	WF	WPD	TH	WF	WPD
°C	°C	kW	m ³ /h	kPa	kW	m ³ /h	kPa	kW	m ³ /h	kPa	kW	m ³ /h	kPa
40	5	5.93	1.03	11.91	5.35	0.93	9.98	4.78	0.83	8.2	4.2	0.73	6.59
	6	5.76	0.83	8.29	5.18	0.75	6.91	4.6	0.66	5.64	4.02	0.58	4.49
	8	5.4	0.58	4.57	4.82	0.52	3.76	4.24	0.46	3.03	3.66	0.4	2.36
	10	5.03	0.44	2.79	4.44	0.38	2.26	3.86	0.33	1.75	3.27	0.28	1.14
	12	4.65	0.33	1.76	4.05	0.29	1.23	3.45	0.25	0.74	2.84	0.2	0.52
45	5	7.36	1.28	16.87	6.77	1.18	14.63	6.19	1.07	12.53	5.62	0.97	10.58
	6	7.18	1.04	11.84	6.6	0.95	10.23	6.02	0.87	8.73	5.45	0.79	7.35
	8	6.84	0.74	6.65	6.25	0.68	5.71	5.67	0.61	4.84	5.09	0.55	4.02
	10	6.48	0.56	4.17	5.89	0.51	3.55	5.31	0.46	2.97	4.73	0.41	2.44
	12	6.11	0.44	2.79	5.52	0.4	2.35	4.93	0.36	1.94	4.34	0.31	1.54
50	5	8.78	1.53	22.47	8.19	1.42	19.92	7.61	1.32	17.52	7.03	1.22	15.27
	6	8.61	1.25	15.85	8.02	1.16	14.02	7.44	1.08	12.31	6.86	0.99	10.7
	8	8.27	0.9	9.01	7.68	0.83	7.94	7.1	0.77	6.93	6.52	0.71	5.99
	10	7.92	0.69	5.73	7.33	0.64	5.02	6.74	0.59	4.35	6.16	0.53	3.73
	12	7.56	0.55	3.89	6.97	0.5	3.39	6.38	0.46	2.92	5.8	0.42	2.48
55	5	10.2	1.78	28.65	9.61	1.67	25.82	9.02	1.57	23.13	8.44	1.47	20.59
	6	10.03	1.46	20.28	9.44	1.37	18.25	8.86	1.28	16.32	8.27	1.2	14.5
	8	9.69	1.05	11.63	9.1	0.99	10.43	8.52	0.93	9.3	7.94	0.86	8.22
	10	9.35	0.81	7.45	8.76	0.76	6.66	8.17	0.71	5.92	7.59	0.66	5.21
	12	9	0.65	5.12	8.41	0.61	4.56	7.82	0.57	4.03	7.24	0.52	3.53
60	5	11.62	2.03	35.38	11.03	1.92	32.28	10.44	1.82	29.32	9.85	1.72	26.5
	6	11.45	1.66	25.11	10.86	1.58	22.88	10.27	1.49	20.76	9.69	1.41	18.73
	8	11.12	1.21	14.48	10.53	1.15	13.16	9.94	1.08	11.91	9.35	1.02	10.72
	10	10.78	0.94	9.34	10.19	0.89	8.47	9.6	0.84	7.64	9.01	0.78	6.86
	12	10.43	0.76	6.47	9.84	0.71	5.85	9.25	0.67	5.26	8.67	0.63	4.7

MUCS-20-W7													
EWT	ΔT	Indoor temperature (D.B.)											
		16			18			20			22		
		TH	WF	WPD	TH	WF	WPD	TH	WF	WPD	TH	WF	WPD
°C	°C	kW	m ³ /h	kPa	kW	m ³ /h	kPa	kW	m ³ /h	kPa	kW	m ³ /h	kPa
40	5	6.1	1.06	12.51	5.51	0.95	10.48	4.92	0.85	8.62	4.32	0.75	6.92
	6	5.92	0.86	8.7	5.33	0.77	7.25	4.73	0.68	5.93	4.14	0.6	4.72
	8	5.56	0.6	4.79	4.96	0.54	3.95	4.36	0.47	3.18	3.76	0.41	2.48
	10	5.18	0.45	2.93	4.57	0.4	2.38	3.97	0.34	1.85	3.36	0.29	1.25
	12	4.78	0.34	1.86	4.17	0.3	1.34	3.55	0.26	0.8	2.92	0.21	0.54
45	5	7.57	1.31	17.73	6.97	1.21	15.37	6.37	1.11	13.17	5.78	1	11.12
	6	7.39	1.07	12.44	6.79	0.98	10.75	6.2	0.9	9.18	5.6	0.81	7.72
	8	7.03	0.76	6.99	6.43	0.7	6	5.84	0.63	5.08	5.24	0.57	4.23
	10	6.66	0.58	4.37	6.06	0.53	3.72	5.46	0.47	3.12	4.86	0.42	2.56
	12	6.28	0.45	2.92	5.68	0.41	2.46	5.07	0.37	2.03	4.47	0.32	1.63
50	5	9.03	1.57	23.62	8.43	1.47	20.94	7.83	1.36	18.42	7.24	1.26	16.05
	6	8.86	1.28	16.65	8.26	1.2	14.74	7.66	1.11	12.93	7.06	1.02	11.24
	8	8.5	0.92	9.47	7.9	0.86	8.34	7.3	0.79	7.28	6.71	0.73	6.29
	10	8.14	0.71	6.01	7.54	0.65	5.27	6.94	0.6	4.57	6.34	0.55	3.92
	12	7.77	0.56	4.09	7.17	0.52	3.56	6.57	0.47	3.07	5.96	0.43	2.6
55	5	10.49	1.83	30.12	9.89	1.72	27.15	9.29	1.62	24.33	8.69	1.51	21.65
	6	10.32	1.5	21.31	9.72	1.41	19.18	9.12	1.32	17.16	8.52	1.24	15.25
	8	9.97	1.08	12.22	9.37	1.02	10.96	8.77	0.95	9.77	8.17	0.89	8.64
	10	9.62	0.84	7.83	9.01	0.78	7	8.41	0.73	6.21	7.81	0.68	5.47
	12	9.26	0.67	5.38	8.65	0.63	4.79	8.05	0.58	4.23	7.45	0.54	3.71
60	5	11.96	2.08	37.21	11.35	1.98	33.95	10.74	1.87	30.84	10.14	1.77	27.87
	6	11.78	1.71	26.4	11.18	1.62	24.06	10.57	1.54	21.83	9.97	1.45	19.7
	8	11.44	1.25	15.21	10.83	1.18	13.83	10.23	1.11	12.52	9.63	1.05	11.27
	10	11.09	0.97	9.82	10.48	0.91	8.9	9.88	0.86	8.03	9.27	0.81	7.21
	12	10.73	0.78	6.8	10.13	0.73	6.15	9.52	0.69	5.53	8.92	0.65	4.94

Abbreviations:

Δt: Temperature Difference (°C) **TH:** Total Heating Capacity (kW) **WF:** Water Flow (m³/h) **WPD:** Water Pressure Drop (kPa)

(none)													
EWT	ΔT	Indoor temperature (D.B.)											
		16			18			20			22		
		TH	WF	WPD	TH	WF	WPD	TH	WF	WPD	TH	WF	WPD
°C	°C	kW	m ³ /h	kPa	kW	m ³ /h	kPa	kW	m ³ /h	kPa	kW	m ³ /h	kPa
40	5	7.83	1.36	9.55	7.06	1.22	8	6.3	1.09	6.58	5.54	0.96	5.28
	6	7.6	1.1	6.66	6.83	0.99	5.55	6.07	0.88	4.54	5.31	0.77	3.61
	8	7.13	0.77	3.68	6.36	0.69	3.03	5.6	0.61	2.44	4.83	0.52	1.9
	10	6.65	0.58	2.25	5.87	0.51	1.81	5.1	0.44	1.29	4.32	0.37	0.75
45	5	9.71	1.68	13.51	8.94	1.55	11.71	8.17	1.42	10.03	7.41	1.29	8.47
	6	9.48	1.37	9.49	8.71	1.26	8.2	7.94	1.15	7	7.18	1.04	5.89
	8	9.02	0.98	5.35	8.25	0.89	4.59	7.48	0.81	3.89	6.72	0.73	3.24
	10	8.56	0.74	3.36	7.78	0.67	2.86	7.01	0.61	2.4	6.24	0.54	1.97
50	5	11.58	2.01	17.97	10.8	1.88	15.93	10.03	1.74	14	9.27	1.61	12.2
	6	11.36	1.64	12.69	10.58	1.53	11.22	9.81	1.42	9.85	9.04	1.31	8.56
	8	10.91	1.18	7.23	10.13	1.1	6.37	9.36	1.02	5.56	8.59	0.93	4.8
	10	10.45	0.91	4.6	9.67	0.84	4.03	8.9	0.77	3.5	8.13	0.71	3
55	5	13.45	2.34	22.88	12.67	2.21	20.62	11.9	2.07	18.46	11.12	1.94	16.43
	6	13.23	1.92	16.21	12.45	1.81	14.58	11.68	1.69	13.04	10.91	1.58	11.58
	8	12.79	1.39	9.31	12.01	1.31	8.35	11.23	1.22	7.44	10.46	1.14	6.58
	10	12.34	1.07	5.98	11.56	1	5.35	10.78	0.94	4.74	10.01	0.87	4.18
60	5	15.33	2.67	28.24	14.54	2.54	25.75	13.76	2.4	23.38	12.98	2.26	21.12
	6	15.11	2.2	20.05	14.32	2.08	18.27	13.54	1.97	16.56	12.77	1.86	14.94
	8	14.67	1.6	11.58	13.88	1.51	10.52	13.1	1.43	9.52	12.33	1.34	8.56
	10	14.22	1.24	7.48	13.44	1.17	6.79	12.66	1.1	6.12	11.88	1.03	5.49
12	13.77	1	5.19	12.99	0.94	4.69	12.2	0.89	4.22	11.43	0.83	3.77	

(none)													
EWT	ΔT	Indoor temperature (D.B.)											
		16			18			20			22		
		TH	WF	WPD	TH	WF	WPD	TH	WF	WPD	TH	WF	WPD
°C	°C	kW	m ³ /h	kPa	kW	m ³ /h	kPa	kW	m ³ /h	kPa	kW	m ³ /h	kPa
40	5	8.24	1.43	10.43	7.43	1.29	8.74	6.63	1.15	7.18	5.83	1.01	5.77
	6	8	1.15	7.27	7.19	1.04	6.06	6.39	0.92	4.95	5.59	0.81	3.94
	8	7.51	0.81	4.01	6.7	0.72	3.31	5.89	0.64	2.66	5.08	0.55	2.07
	10	7	0.61	2.46	6.18	0.53	1.98	5.36	0.46	1.48	4.54	0.39	0.88
45	5	10.22	1.77	14.76	9.4	1.63	12.79	8.6	1.49	10.96	7.79	1.35	9.25
	6	9.98	1.44	10.37	9.17	1.33	8.96	8.36	1.21	7.64	7.56	1.09	6.43
	8	9.5	1.03	5.84	8.68	0.94	5.01	7.88	0.85	4.24	7.07	0.77	3.53
	10	9	0.78	3.66	8.19	0.71	3.12	7.37	0.64	2.61	6.56	0.57	2.14
50	5	12.19	2.12	19.64	11.37	1.98	17.41	10.56	1.84	15.31	9.75	1.7	13.33
	6	11.95	1.73	13.86	11.14	1.61	12.26	10.33	1.5	10.76	9.52	1.38	9.35
	8	11.48	1.25	7.89	10.66	1.16	6.95	9.85	1.07	6.07	9.04	0.98	5.24
	10	11	0.95	5.02	10.18	0.88	4.4	9.37	0.81	3.82	8.55	0.74	3.27
55	5	14.16	2.46	25.03	13.34	2.32	22.54	12.52	2.18	20.19	11.71	2.04	17.96
	6	13.93	2.02	17.72	13.11	1.9	15.94	12.29	1.78	14.26	11.48	1.67	12.66
	8	13.46	1.46	10.17	12.64	1.37	9.12	11.82	1.29	8.13	11.01	1.2	7.19
	10	12.99	1.13	6.53	12.16	1.06	5.84	11.35	0.99	5.18	10.53	0.92	4.56
60	5	16.13	2.81	30.89	15.3	2.67	28.17	14.48	2.53	25.57	13.66	2.38	23.1
	6	15.9	2.31	21.93	15.07	2.19	19.98	14.25	2.07	18.11	13.44	1.95	16.34
	8	15.44	1.68	12.66	14.61	1.59	11.5	13.79	1.5	10.4	12.97	1.41	9.36
	10	14.97	1.3	8.18	14.14	1.23	7.41	13.32	1.16	6.68	12.5	1.09	5.99
12	14.49	1.05	5.67	13.67	0.99	5.12	12.84	0.93	4.61	12.03	0.87	4.11	

Abbreviations:

Δt: Temperature Difference (°C) TH: Total Heating Capacity (kW) WF: Water Flow (m³/h) WPD: Water Pressure Drop (kPa)

MUCS-24-W7													
EWT	ΔT	Indoor temperature (D.B.)											
		16			18			20			22		
		TH	WF	WPD	TH	WF	WPD	TH	WF	WPD	TH	WF	WPD
[°C]	[°C]	[kW]	[m ³ /h]	[kPa]	[kW]	[m ³ /h]	[kPa]	[kW]	[m ³ /h]	[kPa]	[kW]	[m ³ /h]	[kPa]
40	5	8.61	1.49	11.26	7.77	1.35	9.43	6.93	1.2	7.75	6.1	1.06	6.22
	6	8.36	1.21	7.84	7.52	1.09	6.53	6.68	0.96	5.33	5.84	0.84	4.25
	8	7.85	0.85	4.33	7	0.76	3.56	6.15	0.67	2.87	5.31	0.57	2.23
	10	7.31	0.63	2.65	6.46	0.56	2.14	5.6	0.48	1.64	4.74	0.41	1.03
	12	6.75	0.49	1.64	5.89	0.42	1.11	5.02	0.36	0.68	4.13	0.3	0.51
45	5	10.68	1.85	15.94	9.83	1.71	13.81	8.99	1.56	11.82	8.15	1.41	9.98
	6	10.43	1.51	11.19	9.58	1.39	9.67	8.74	1.26	8.25	7.9	1.14	6.93
	8	9.93	1.08	6.3	9.08	0.98	5.4	8.23	0.89	4.57	7.39	0.8	3.8
	10	9.41	0.82	3.95	8.56	0.74	3.36	7.71	0.67	2.81	6.86	0.59	2.31
	12	8.88	0.64	2.64	8.02	0.58	2.22	7.16	0.52	1.83	6.3	0.45	1.44
50	5	12.74	2.21	21.22	11.89	2.07	18.8	11.04	1.92	16.53	10.19	1.77	14.39
	6	12.5	1.81	14.97	11.64	1.69	13.24	10.79	1.56	11.61	9.95	1.44	10.08
	8	12	1.3	8.52	11.15	1.21	7.5	10.3	1.12	6.55	9.45	1.03	5.65
	10	11.5	1	5.42	10.64	0.92	4.75	9.79	0.85	4.12	8.94	0.78	3.53
	12	10.98	0.79	3.69	10.12	0.73	3.21	9.26	0.67	2.76	8.41	0.61	2.35
55	5	14.8	2.58	27.04	13.94	2.43	24.36	13.09	2.28	21.81	12.24	2.13	19.39
	6	14.56	2.11	19.15	13.7	1.99	17.22	12.85	1.86	15.39	12	1.74	13.67
	8	14.07	1.53	10.98	13.21	1.44	9.85	12.36	1.34	8.77	11.51	1.25	7.76
	10	13.57	1.18	7.05	12.71	1.11	6.3	11.86	1.03	5.59	11.01	0.96	4.92
	12	13.07	0.95	4.85	12.21	0.88	4.31	11.35	0.82	3.81	10.5	0.76	3.33
60	5	16.86	2.94	33.39	16	2.79	30.44	15.14	2.64	27.63	14.28	2.49	24.95
	6	16.62	2.42	23.7	15.76	2.29	21.58	14.9	2.17	19.57	14.04	2.04	17.65
	8	16.14	1.76	13.67	15.27	1.66	12.42	14.41	1.57	11.23	13.56	1.48	10.1
	10	15.65	1.36	8.83	14.78	1.29	8	13.92	1.21	7.21	13.07	1.14	6.47
	12	15.15	1.1	6.12	14.28	1.04	5.53	13.42	0.97	4.97	12.57	0.91	4.44

MUCS-36-W7													
EWT	ΔT	Indoor temperature (D.B.)											
		16			18			20			22		
		TH	WF	WPD	TH	WF	WPD	TH	WF	WPD	TH	WF	WPD
[°C]	[°C]	[kW]	[m ³ /h]	[kPa]	[kW]	[m ³ /h]	[kPa]	[kW]	[m ³ /h]	[kPa]	[kW]	[m ³ /h]	[kPa]
40	5	10.71	1.86	8.51	9.66	1.67	7.13	8.61	1.49	5.86	7.57	1.31	4.7
	6	10.4	1.5	5.94	9.35	1.35	4.95	8.3	1.2	4.05	7.26	1.05	3.22
	8	9.77	1.06	3.29	8.71	0.94	2.71	7.66	0.83	2.18	6.61	0.71	1.66
	10	9.11	0.79	2.01	8.05	0.7	1.55	6.98	0.6	1.01	5.91	0.51	0.62
	12	8.43	0.61	1	7.35	0.53	0.67	6.26	0.45	0.53	5.16	0.37	0.44
45	5	13.27	2.3	12.02	12.21	2.12	10.41	11.16	1.94	8.91	10.11	1.75	7.52
	6	12.96	1.87	8.45	11.9	1.72	7.3	10.85	1.57	6.23	9.8	1.42	5.24
	8	12.35	1.34	4.77	11.29	1.22	4.1	10.23	1.11	3.47	9.18	0.99	2.88
	10	11.71	1.01	3	10.65	0.92	2.56	9.59	0.83	2.14	8.53	0.74	1.75
	12	11.06	0.8	2.01	9.99	0.72	1.68	8.92	0.64	1.32	7.85	0.57	0.9
50	5	15.83	2.75	15.96	14.76	2.57	14.14	13.7	2.38	12.42	12.64	2.2	10.81
	6	15.53	2.25	11.28	14.46	2.09	9.97	13.4	1.94	8.74	12.34	1.79	7.59
	8	14.92	1.62	6.44	13.85	1.5	5.67	12.79	1.39	4.95	11.73	1.27	4.27
	10	14.3	1.24	4.11	13.23	1.15	3.6	12.17	1.06	3.12	11.11	0.96	2.67
	12	13.66	0.99	2.8	12.59	0.91	2.44	11.52	0.83	2.1	10.46	0.76	1.78
55	5	18.38	3.2	20.31	17.3	3.01	18.28	16.24	2.83	16.36	15.17	2.64	14.54
	6	18.08	2.62	14.4	17.01	2.47	12.94	15.94	2.31	11.56	14.88	2.16	10.26
	8	17.48	1.9	8.28	16.41	1.78	7.42	15.34	1.67	6.61	14.28	1.55	5.84
	10	16.87	1.47	5.33	15.8	1.37	4.76	14.73	1.28	4.22	13.67	1.19	3.72
	12	16.25	1.18	3.67	15.18	1.1	3.27	14.11	1.02	2.89	13.04	0.94	2.53
60	5	20.94	3.65	25.03	19.85	3.46	22.81	18.77	3.28	20.69	17.7	3.09	18.67
	6	20.64	3	17.79	19.56	2.84	16.19	18.48	2.69	14.67	17.41	2.53	13.23
	8	20.05	2.18	10.29	18.96	2.07	9.34	17.89	1.95	8.45	16.82	1.83	7.59
	10	19.45	1.69	6.66	18.36	1.6	6.03	17.29	1.51	5.44	16.22	1.41	4.87
	12	18.83	1.37	4.63	17.75	1.29	4.18	16.67	1.21	3.76	15.61	1.13	3.35

Abbreviations:

Δt: Temperature Difference (°C) TH: Total Heating Capacity (kW) WF: Water Flow (m³/h) WPD: Water Pressure Drop (kPa)

7. Sound Levels

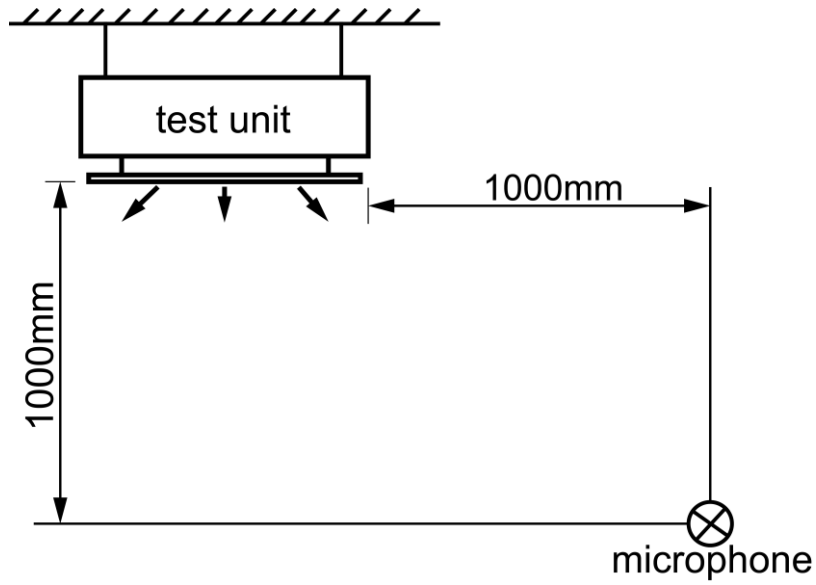

	MUCS-20-W7	MUCS-24-W7	MUCS-36-W7
H/M/L [dB(A)]	44/40/34	48/44/41	49/43/39

8. Dimension

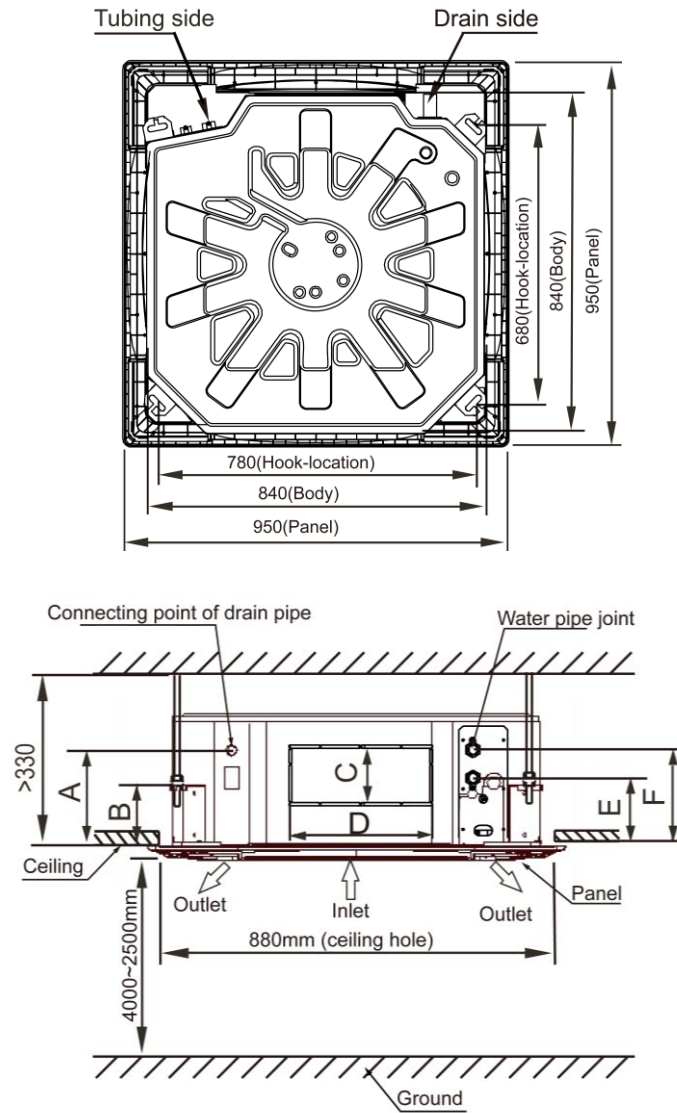

Model	A	B	C	D	E	F
MUCS-20-W7	180	140	85	350	145	195
MUCS-24/36-W7	180	140	155	350	155	205

9. Service Spaces

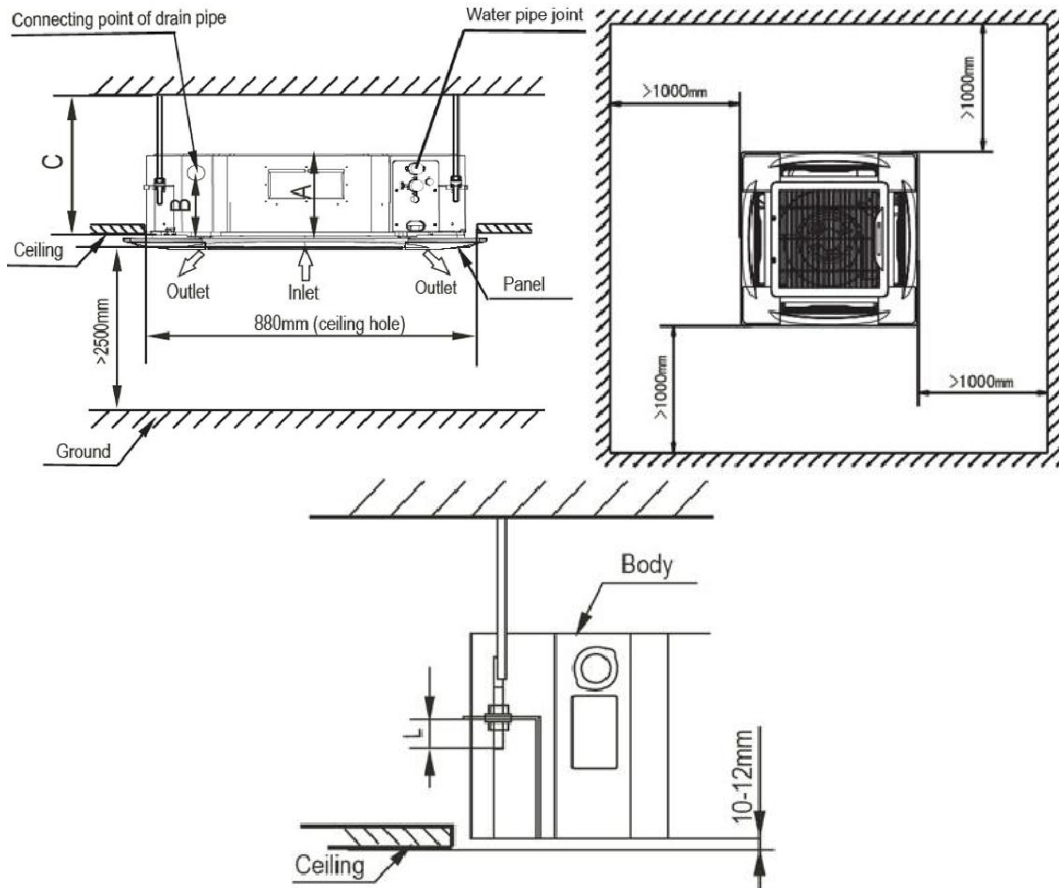

Model	A	B	C
MUCS-20-W7	230	170	>260
MUCS-24/36-W7	300	190	>330

10. Wiring Diagrams

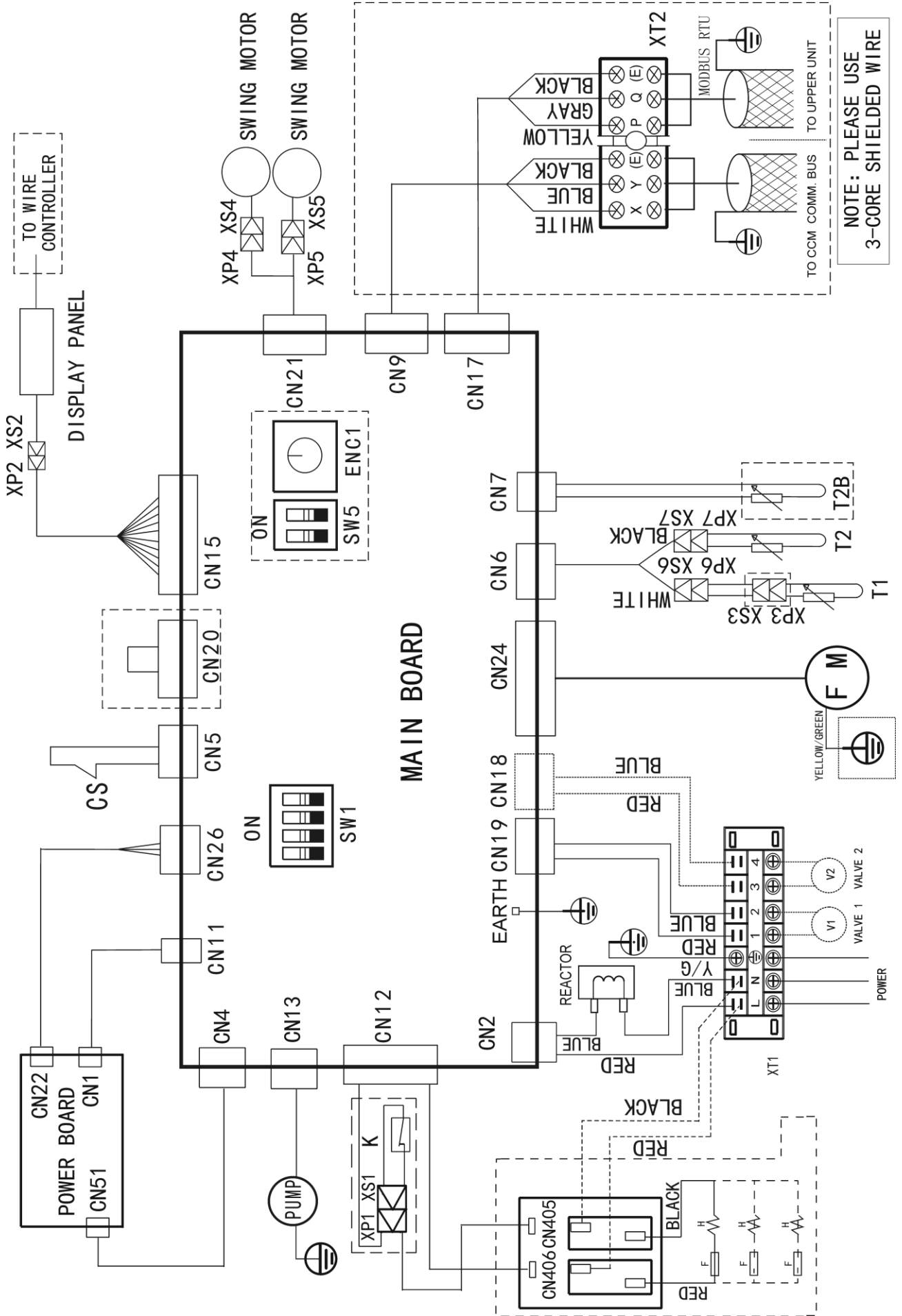







Table A













CODE	DESCRIPTION
FM	FAN MOTOR
V1-2	WATER VALVE
T1	ROOM TEMP. SENSOR
T2	PIPE TEMP. SENSOR
T2B	PIPE TEMP. SENSOR
XP1-7, XS1-7	CONNECTORS
XT1	TERMINAL
XT2	TERMINAL
F	FUSE
K	PROTECTOR SWITCH OVER HEAT
H	AUXILIARY HEATER
CS	WATER LEVEL SWITCH
PUMP	PUMP MOTOR

MODEL	DIP SW1
(none)	
MUCS-20-W7	
(none)	
(none)	
MUCS-24-W7	
MUCS-36-W7	

Notes:

1. SW1 must be set as the Table B.
2. Two control mode is only connected with a valve (valve 1); Four control models are respectively connected with the valve 1 and valve 2.

Every air-conditioner in network has only one network address to distinguish each other. Address code of air-conditioner in LAN is set by code switch on Network Interface Module (NIM), and the set range is 0-63.

Toggle switch set			Network address code
SW5	ENC1		
			00~15
			16~31
			32~47
			48~63

11. Troubleshooting

Troubles and causes of air conditioner

If one of the following malfunctions occur, stop operation, shut off the power, and contact with your dealer.

- The operation lamp is flashing rapidly (five times per second), you disconnect the unit with the power and then connect the unit with the power again after two or three minutes but the lamps still flash.
- Switch operations are erratic.
- The fuse is blown frequently or the circuit breaker is tripped frequently.
- Foreign matter or water has fallen inside the air conditioner.
- Water leaks from the indoor unit.

If the system does not properly operate except the above mentioned cases or the above mentioned malfunctions are evident, investigate the system according to the following procedures.

Symptoms	Causes	Solution
Unit does not start.	<ul style="list-style-type: none"> • Power failure/ • Power switch is off. • Fuse of power switch may have burned. • Batteries of remote controller exhausted or other problem of controller. 	<ul style="list-style-type: none"> • Wait for the comeback of power. • Switch on the power. • Replace the fuse. • Replace the batteries or check the controller.
Air flowing normally but completely can't cooling.	<ul style="list-style-type: none"> • Temperature is not set correctly. 	<ul style="list-style-type: none"> • Set the temperature properly.
Units start or stop frequently.	<ul style="list-style-type: none"> • Air or no concentering gas in the watering circuit. • Three-way valve is malfunction. • Voltage is too high or too low. • System circuit is blocked. • Temperature is not set correctly. 	<ul style="list-style-type: none"> • Vacuum. • Maintenance or change three-way valve. • Install manostat. • Find reasons and solution.
Low cooling effect.	<ul style="list-style-type: none"> • Indoor unit heat exchanger is dirty. • The air filter is dirty. • Inlet/outlet od indoor unit is blocked. • Doors and windows are open, sunlight directly shine. • Too much heat source. • Leakage of water. 	<ul style="list-style-type: none"> • Clean the heat exchanger. • Clean the air filter. • Eliminate all dirties and make air smooth. • Close doors and windows. • Make curtains in order to shelter from sunshine. • Reduce heat source. • AC cooling capacity reduces (normal). • Check leakage.
Low heating effect.	<ul style="list-style-type: none"> • Doors and windows not completely closed. • Leakage of water. 	<ul style="list-style-type: none"> • Use heating device. • Close doors and windows. • Check leakage.

Troubles and causes of remote controller

Before asking for serving or repairing, check the following points.

Symptoms	Causes	Solution
The fan speed cannot be changed.	• Check whether the MODE indicated on the display is "AUTO"	When the automatic mode is selected, the air conditioner will automatically change the fan speed.
	• Check whether the MODE indicated on the display is "DRY".	When dry operation is selected, the air conditioner changes the fan speed automatically. The fan speed can be selected during "COOL", "FAN ONLY", and "HEAT".
The remote controller signal is not transmitted even when the ON/OFF button is pushed.	• Check whether the batteries in the remote controller are exhausted.	The power supply is off.
The TEMP. indicator does not come on.	• Check whether the MODE indicated on display is FAN ONLY.	The temperature cannot be set during FAN mode.
The indication on the display disappears after a lapse of certain time.	• Check whether the timer operation has come to an end when the TIMER OFF is indicated on the display.	The air conditioner operation will stop up to the set time.
The TIMER on indicator goes off after a lapse of certain time.	• Check whether the timer operation is started when the TIMER ON is indicated on the display.	Up to the set time, the air conditioner will automatically start and the appropriate indicator will go off.
No receiving tone sounds from the indoor unit even when the ON/OFF button is pressed.	• Check whether the signal transmitter of the remote controller is properly directed to the infrared signal receiver of the indoor unit when the ON/OFF button is pressed.	Directly transmit the signal transmitter of the remote controller to the infrared signal receiver of the indoor unit, and then repeatedly push the ON/OFF button twice.

Malfunctions and malfunction code

If anything happens like the situation described below, please shut off the power supply of the unit and contact with the customer service center immediately.

NO.	Malfunction	running lamp	timer lamp	defrosting lamp	alarm lamp	alarm lamp
1	Room temperature sensor check channel is abnormal.	×	☆	×	×	E2
2	Evaporator sensor checking channel is abnormal.	☆	×	×	×	E3
3	EEprom malfunction.	☆	☆	×	×	E7
4	Water-level switch malfunction.	×	×	×	☆	EE
5	Fan failure.	☆	×	☆	×	E8
6	Not set models.	×	×	☆	☆	PH

Note: × Extinguish, ☆ Flash at 5Hz.

12. Installation

12.1 Before Installation

Please check whether the accessories are of full scope. If there are some fittings free from use, please restore them carefully.

12.2 Installation space

(Refer to fig.12.1, fig.12.2, fig.12.3 and table 12.1 for specification.)

The indoor unit should be installed in a location that meets the following requirements:

- There is enough room for installation and maintenance.
- The ceiling is horizontal, and its structure can bear the weight of the indoor unit.
- The outlet and the inlet are not impeded, and the influence of external air is the least.
- The air flow can reach throughout the room.
- The connecting water pipe and drainpipe could be extracted out easily.
- There is no direct radiation from heaters.

Caution: Keep indoor unit, outdoor unit, power supply wiring and transmission wiring at least 1 meter away from televisions and radios. This is to prevent image interference and noise in those electrical appliances. (Noise may be generated depending on the conditions under which the electric wave is generated, even if 1 meter is kept.)

12.3 Installation procedures for fresh air intake duct connection

Preparing the connection hole

- Cut off the knockout hole on the side plate with a nipper.
- Cut the inner insulation of the hole portion with a cutter.

Placing the insulation

- Put the insulation tightly around the hole of the unit as shown.
- The ends of the side plate and the inner insulation must be completely adhered without leaving any clearance along the circumference of the hole. Make sure the inner surface of insulation tightly contacts the inner insulation edge and the side plate. (refer to fig.12.5)

12.4 Install the Main Body

A. The existing ceiling (to be horizontal)

- a. Cut a quadrangular hole of 880×880mm in the ceiling according to the shape of the installation paper board.
 - The center of the hole should be at the same position of that of the air conditioner body.
 - Determine the lengths and outlets of the connecting pipe, drain pipe and cables.
 - To balance the ceiling and to avoid vibration, please enforce the ceiling when necessary.
- b. Select the position of installation hooks according to the hook holes on the installation board.
 - Drill four holes of Ø12mm, 50~55mm deep at the selected positions on the ceiling. Then embed the expansible hooks (fittings).
 - Face the concave side of the installation hooks toward the expansible hooks. Determine the length of the installation hooks from the height of ceiling, and then cut off the unnecessary part.
 - If the ceiling is extremely high, please determine the length of the installation hook according to facts.
- c. Adjust the hexangular nuts on the four installation hooks evenly, to ensure the balance of the body.
 - If the drainpipe is awry, leakage will be caused by the malfunction of the water-level switch.

- Adjust the position to ensure the gaps between the body and the four sides of ceiling are even. The body's lower part should sink into the ceiling for 10~12 mm (refer to fig.12.6).
- In general, L is half of the screw length of the installation hook. (refer to fig.12.6)
- Locate the air conditioner firmly by wrenching the nuts after having adjusted the body's position well. (refer to fig.12.7)

B. New built houses and ceilings

- In the case of new built house, the hook can be embedded in advance (refer to the A.b mentioned above). But it should be strong enough to bear the indoor unit and will not become loose because of concrete shrinking.
- After installing the body, please fasten the installation paper board onto the air conditioner with bolts (M6×12) to determine in advance the sizes and positions of the hole opening on ceiling. (refer to fig.12.8)
 - Please first guarantee the flatness and horizontal of ceiling when installing it.
 - Refer to the A.a mentioned above for others.
- Refer to the A.c mentioned above for installation.
- Remove the installation paper board.

Caution: After installing the body, the four bolts (M6x12) must be fastened to the air conditioner onto ensure the body is grounded well.

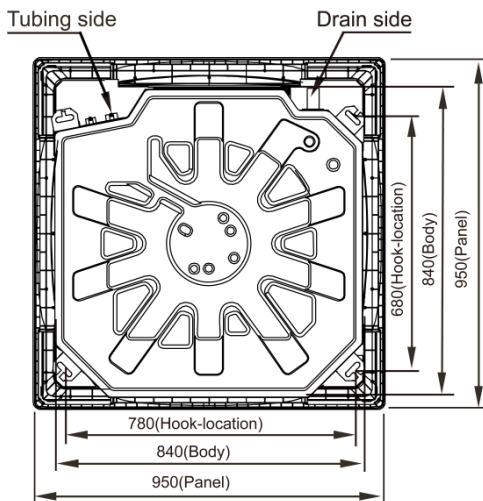

fig. 12.1

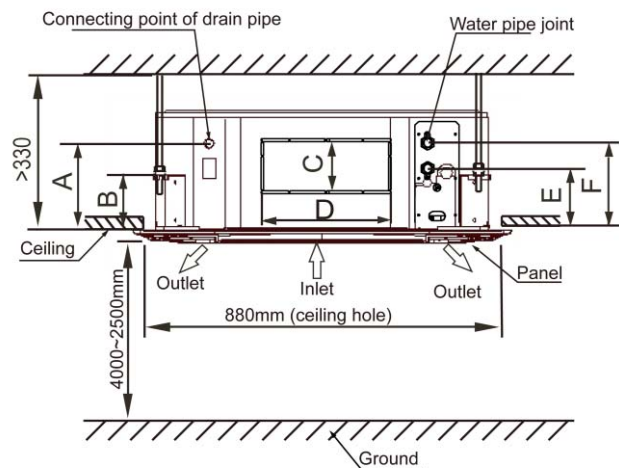

fig. 12.2

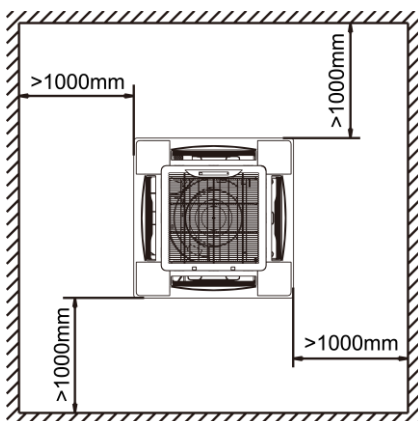

fig. 12.3

Table 12.1

Model	A	B	C	D	E	F
MUCS-20-W7	180	140	85	350	145	195
MUCS-24/36-W7	180	140	155	350	155	205

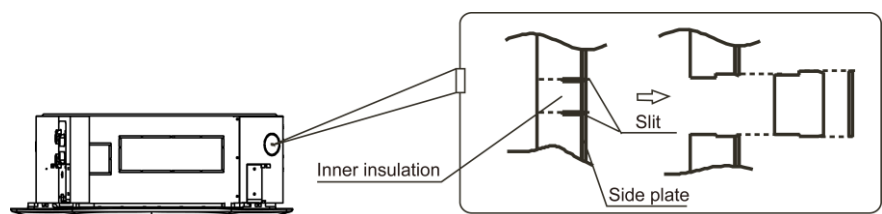

fig. 12.4

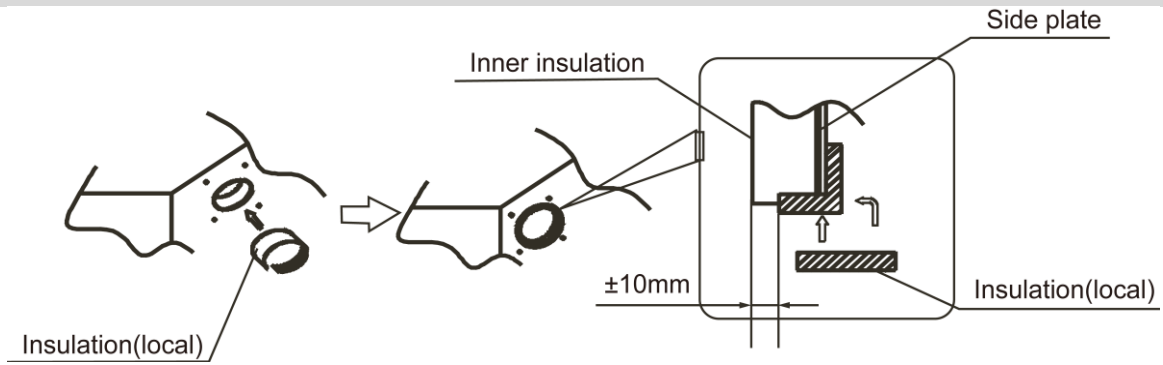

fig. 12.5

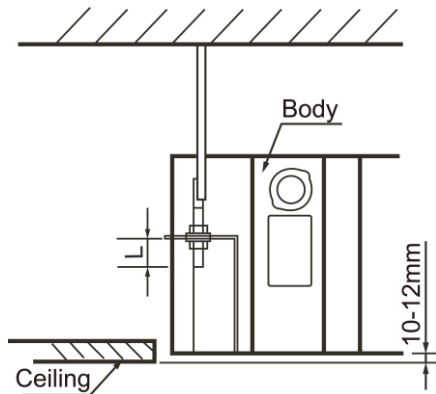

fig. 12.6

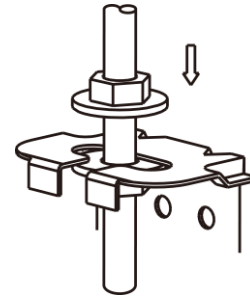

fig. 12.7

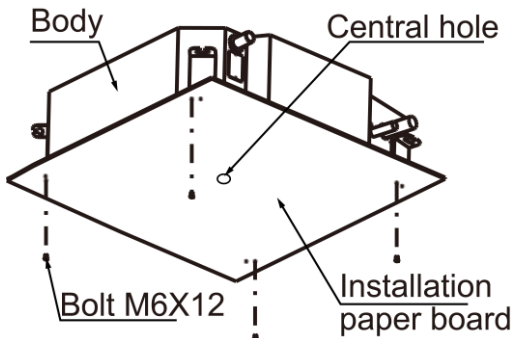

fig. 12.8

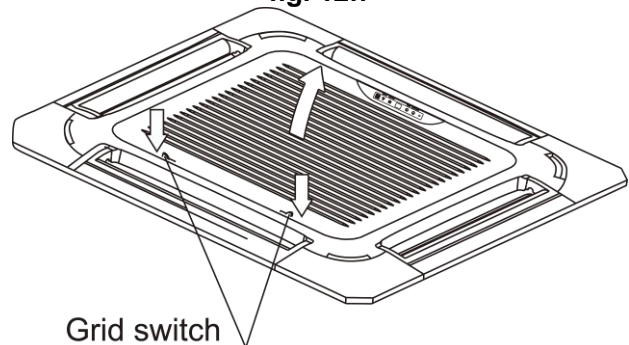

fig. 12.9

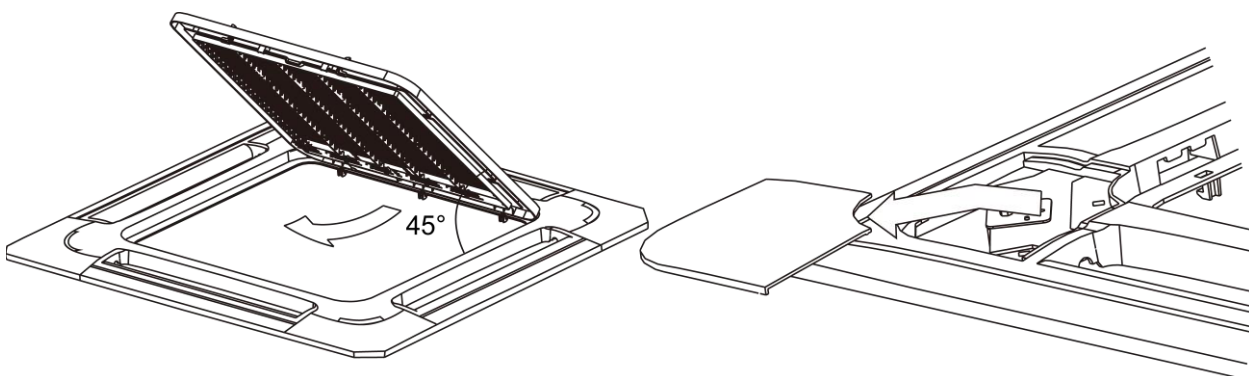

fig. 12.10

12.5 Install the Panel

Caution:

Never put the panel face down on floor or against the wall, or on bulgy objects.

Never crash or strike it.

(1) Remove the air inlet grill.

- a. Slide two grid switches toward the middle at the same time, and then pull them up. (Refer to fig. 12.9)
- b. Draw the grid up to an angle of about 45°, and remove it. (Refer to fig. 12.10)

(2) Remove the installation covers at the four corners.

Wrench off the bolts, loose the rope of the installation covers, and remove them. (Refer to fig. 12.10)

(3) Install the panel

- a. Align the swing motor on the panel to the tubing joints of the body properly.
- b. Fix hooks of the panel at swing motor and its opposite sides to the hooks of corresponding water receiver. Then hang the other two panel hooks onto corresponding hangers of the body.

Caution: Do not coil the wiring of the swing motor into the seal sponge.

- c. Adjust the four panel hook screws to keep the panel horizontal, and screw them up to the ceiling evenly.
- d. Regulate the panel in the direction of the arrow slightly to fit the panel's center to the center of the ceiling's opening. Guarantee that hooks of four corners are fixed well.
- e. Keep fastening the screws under the panel hooks, until the thickness of the sponge between the body and the panel's outlet has been reduced to about 4~6mm. The edge of the panel should contact with the ceiling well.
 - If the gap between the panel and ceiling still exists after fastening the screws, the height of the indoor unit should be modified again.
 - You can modify the height of the indoor unit through the openings on the panel's four corners; if the lift of the indoor unit and the drainpipe is not influenced.

(4) Hang the air-in grid to the panel, and then connect the lead terminator of the swing motor and that of the control box with corresponding terminators on the body respectively.

(5) Relocate the air-in grid in the procedure of reversed order.

(6) Relocate the installation cover.

- a. Fasten the rope of installation cover on the bolt of the installation cover.
- b. Press the installation cover into the panel slightly.

11.6 Connect the Drain Pipe

Install the drainpipe of the indoor unit

- The drainpipe can use PVC pipe (external diameter about 37~39mm, inner diameter is 32mm).
- Joint drainpipe connector to the end side of water pumping pipe, and fix drainpipe together with water outflow pipe and thermal insulation tube by clasp of water outflow pipe (attached).

Caution: Don't use forcing strength to crack the water-pumping pipe.
- Water-pumping pipe and drainpipe from main body must be wrapped by insulation tube evenly, and bound by tighten band for obstructing air getting in and coagulation.
- Prevent from water backflow into unit inside during shutdown, the drain pipe shall place down side and drain water to outdoor (drain side), the gradient of the drain pipe should be higher than (1/100), without salient and water remain.(Refer to fig.12.11 a)
- When connecting drainpipe, don't drag the pipe that would pull the main unit. For this, please arrange bearing points every 0.8 to 1.0 meter to avoid pipe be bended (See fig.12.11 b).
- When connect a lengthen drainpipe, apply protective tube to wrap its indoor parts for ensuring the lengthen part connected tightly.
- In case the drainpipe outlet is higher than pumping connective pipe of the main body, the drainpipe must be arranged upwards vertically by using connective assembly of the water outlet for vertical bending, and the height of the drainpipe shall set to the defrosting pan surface no more than 1000mm, otherwise, too much

backflow while shutdown would leads to overflow (refer to fig.12.12).

- Base on the actual requirement to bend piping, and use connective assembly of water outlet in terminal box for pipe layout.

Caution: The joints in drain system must be sealed to avoid water leakage.

- The height from floor to the end of drainpipe or the bottom of drain slot must more than 50 mm. Don't immerse the end of drainpipe or the bottom of drain slot into water. When drain condensate liquid to raceway, please bend the drainpipe to a U-shaped hydroseal for avoiding stench transmitted by drainpipe to indoor.

Note: All the pictures in this manual are for explanation purpose only. They may be slightly different from the air conditioner you purchased (depend on model).The actual shape shall prevail.

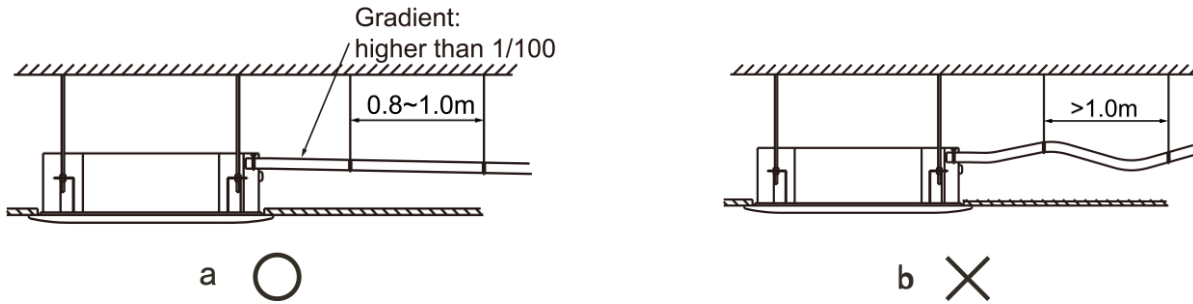

fig. 12.11

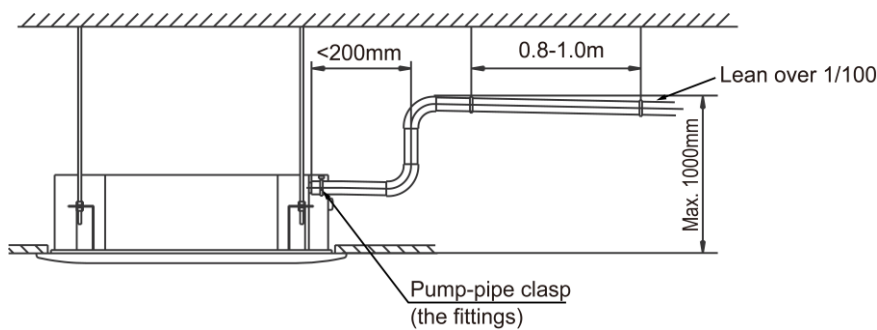

fig. 12.12

Drainage test

- Check whether the drainpipe is unhindered
 - New built house should have this test done before paving the ceiling.
1. Remove the test cover, and stow water of about 2000ml to the water receiver through the stow tube.
 2. Turn on the power, and operate the air conditioner under the "COOLING" mode. Listen to the sound of the drain pump. Check whether the water is discharged well (a lag of 1min is allowed before discharging, according to the length of the drain pipe), and check whether water leaks from the joints.

Caution: If there is any malfunction, please resolve it immediately.

3. Stop the air conditioner for three minutes, check if everything is ok. If the drain hose is located unreasonable, water overflow will cause the Alarm indicator lamp flashing (For both cooling and heating type or cooling only type), even the water leak out from the water receiver.
4. Check the drain pump whether drain water immediately when alarm sound for the high water lever. If the water lever can't come down below to the limited water lever, the air conditioner will stop. Restart it until turn off the power and drain off all the water.
5. Turn off the power, drain the water away.

- The drain plug is used to empty the water-receiver for maintenance of the air conditioner. Please stuff it imposition at all times during operation to avoid leakage.

12.7 Wiring

Caution:

- The air conditioner should use separate power supply with rated voltage.
- The external power supply to the air conditioner should have ground wiring, which is linked to the ground wiring of the indoor and outdoor unit.
- The wiring work should be done by qualified persons according to circuit drawing.
- An all-pole disconnection device which has at least 3mm separation distance in all pole and a residual current device (RCD) with the rating of above 10mA shall be incorporated in the fixed wiring according to the national rule.
- The appliance shall be installed in accordance with national wiring regulations.
- Be sure to locate the power wiring and the signal wirings well to avoid cross-disturbance.
- Do not turn on the power until you have checked carefully after wiring.

Note: Remark per EMC Directive 2004/108/EC for to prevent flicker impressions during the start of the compressor (technical process), following installation conditions do apply.

1. The power connection for the air conditioner has to be done at the main power distribution. The distribution has to be of low impedance; normally the required impedance reaches at a 32A fusing point.
2. No other equipment has to be connected with this power line.
3. For detailed installation acceptance please refer to your power supplier, if restrictions do apply for products like washing machines, air conditioners or electrical ovens.
4. For power details of the air conditioner refer to the rating plate of the product.
5. For any question contact your local dealer.

12.7.1 Connect the cable

- Disassemble the bolts from the cover.(If there isn't a cover on the outdoor unit, disassemble the bolts from the maintenance board, and pull it in the direction of the arrow to remove the protection board.)
- Connect the connective cables to the terminals as identified with their respective matched numbers on the terminal block of indoor and outdoor units.
- Re-install the cover or the protection board.

AIR FLOW (m ³ /h)		510~2550
POWER	PHASE	1-phase
	FREQUENCY AND VOLT	220-240V~ 50Hz
CIRCUIT BREAKER/FUSE (A)		15/15
INDOOR UNIT POWER WIRING (mm ²)	BELOW 20m	Twisted pair wire 2.5 mm ²
	BELOW 50m	Twisted pair wire 6 mm ²
GROUND WIRING (mm ²)		2.5

(The power cord type designation is H05RN-F or above.)

12.7.2 Wiring figure

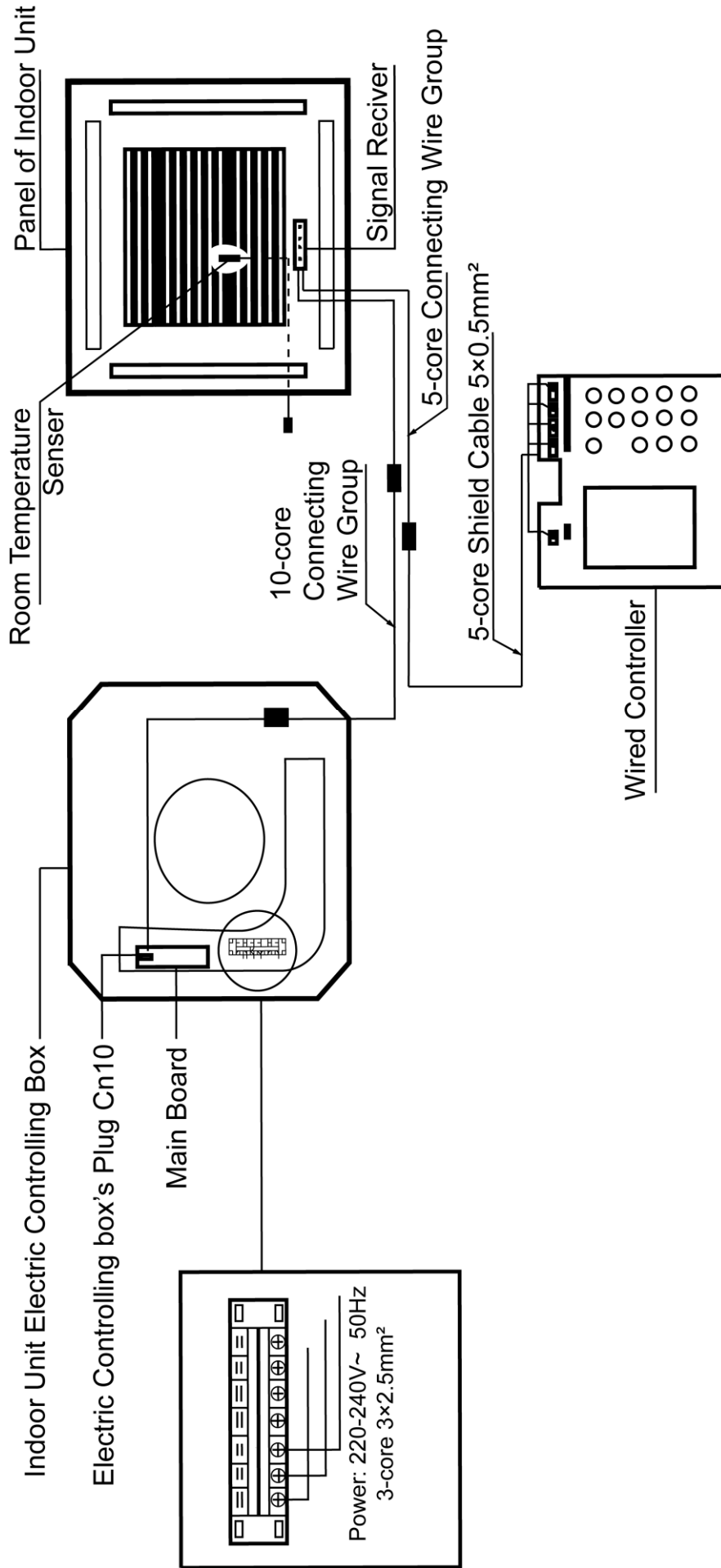

Note: If the supply cord is damaged, it must be replaced by the manufacturer or its service agent or a similarly qualified person in order to avoid a hazard.

12.8 Test operation

- The test operation must be carried out after the entire installation has been completed.
- Please confirm the following points before the test operation:
 - The indoor unit and outdoor unit are installed properly.
 - Tubing and wiring are correctly completed.
 - The water pipe system is leakage-checked. The drainage is unimpeded.
 - The heating insulation works well.
 - The ground wiring is connected correctly.
 - The length of the tubing has been recorded.
 - The power voltage fits the rated voltage of the air conditioner.
 - There is no obstacle at the outlet and inlet of the outdoor and indoor units.
 - The air conditioner is pre-heated by turning on the power.
- According to the user's requirement, install the remote controller frame where the remote controller's signal can reach the indoor unit smoothly.

■ Test operation

Set the air conditioner under the mode of "COOLING" with the remote controller, and check the following points. If there is any malfunction, please resolve it according to the chapter "Troubleshooting" in the "Owner's Manual".

- a. Whether the switch on the remote controller works well.
- b. Whether the buttons on the remote controller works well.
- c. Whether the air flow louver moves normally.
- d. Whether the room temperature is adjusted well.
- e. Whether the indicator lights normally.
- f. Whether the temporary buttons works well.
- g. Whether the drainage is normal.
- h. Whether there is vibration or abnormal noise during operation.
- l. Whether the air conditioner heats well in the case of the HEATING/COOLING type.

Caution: A protection feature prevents the air conditioner from being activated for approximately 3 minutes when it is restarted immediately after shut off.

MUNDO  CLIMA®



www.mundoclima.com

ASK FOR MORE INFORMATION

Phone: (+34) 93 446 27 81

eMail: info@mundoclima.com

TECHNICAL ASSISTANCE

Phone: (+34) 93 652 53 57