

DATASHEET

rev. 02 - 08/03/2023

AIR DYN SYSTEM

heat recovery with thermodynamic system

ACC700001 - ACC700002 - ACC700003
ACC700004 - ACC700005 - ACC700006
ACC700007

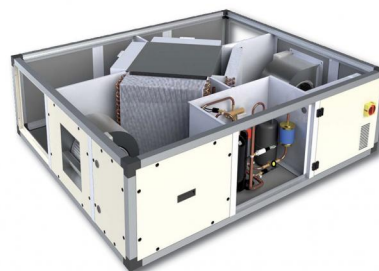

TECHNICAL SPECIFICATIONS:

- Extruded aluminium profile frame
- Sandwich-type infill panels thickness 23 mm
- Synthetic pleated filters in efficiency class ISO 16890 COARSE 55% on both air circuits, large surface
- Optional ePM1 70% filter.
- Cross-flow air-air recovery unit with aluminium plates
- Reversible R410A cooling circuit with hermetic on-off compressor, heat exchange coils with copper pipes and aluminium fins and electronic expansion valve.
- Centrifugal fans with double inlet and directly coupled electric motor at fixed speed
- Internal electrical panel including adjustment and control panel
- Optional remote user terminal

ACCESSORIES

High efficiency filter ePM₁, 70%

Remote user terminal

TECHNICAL DRAWING

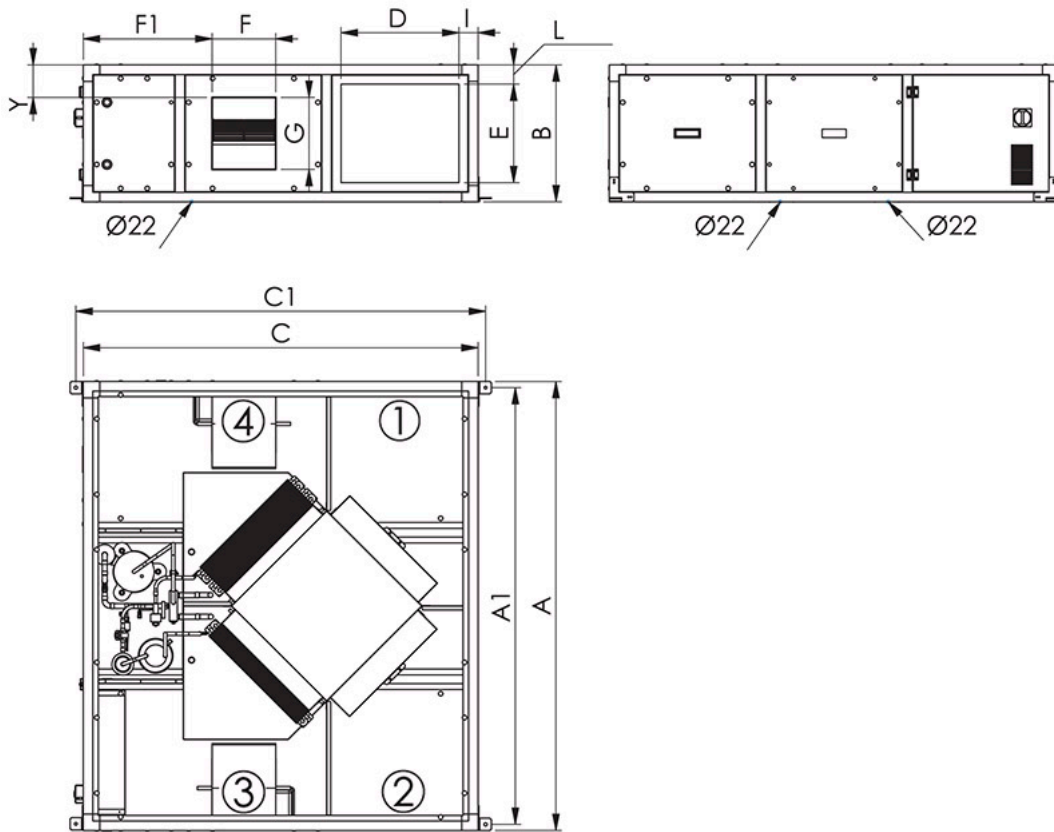

- [1] Outdoor air intake
- [2] Room air intake
- [3] Treated air delivery
- [4] Foul air expulsion

DIMENSIONS

DIMENSIONS	MODEL 1000	MODEL 1500	MODEL 3000
A [mm]	1640		1940
B [mm]	410	500	550
C [mm]	1440		1690
A1 [mm]	1595		1895
C1 [mm]	1494		1744
D [mm]	400		500
E [mm]	250	350	410
F [mm]	233		299
F1 [mm]	703	470	571
G [mm]	264	264	264
I [mm]	85	85	85
L [mm]	80	75	70
Y [mm]	55	118	120

PERFORMANCE

MODEL	1000	1500	2300
Nominal flow rate [m ³ /h]	1000	1500	2300
Available delivery head [Pa]	155	155	155
Available delivery head [Pa]	100	95	95
Sound pressure level [dB(A)]	62/49/54	67/54/57	65/51/59
Weight	185	228	267

LIMITI FUNZIONALI

MODELLO	1000	1500	2300
Condizioni limite invernali configurazione standard [°C]	min -10°C OUT e min 19°C 50% IN	min -10°C OUT e min 19°C 50% IN	min -10°C OUT e min 19°C 50% IN
Campo variazione portata %	-7 ÷ +7	-7 ÷ +7	-7 ÷ +7
Condizioni limite estive [°C]	max 38°C 50% OUT e max 27°C IN	max 38°C 50% OUT e max 27°C IN	max 38°C 50% OUT e max 27°C IN
Campo variazione portata %	-7 ÷ +7	-7 ÷ +7	-7 ÷ +7

DATI ELETTRICI

MODELLO	1000	1500	2300
Alimentazione elettrica [V] / ph / [Hz]	230/1/50	230/1/50	400/3/50
Corrente assorbita max [A]	2430	3710	5440

PRESTAZIONI IN RISCALDAMENTO

MODELLO	1000	1500	2300
Efficienza recupero statico %	50	50	50
Potenza termica totale [W]	9410	14390	21190
Potenza termica recupero attivo [W]	5010	7690	11090
Perdita di carico lato acqua [kPa]	5	18	23
Perdita di carico lato aria [Pa]	43	34	37

PRESTAZIONI IN RAFFRESCAMENTO

MODELLO	1000	1500	2300
Efficienza recupero statico %	950	1450	2250
Potenza frigorifera totale [W]	5840	8720	12830
Potenza frigorifera a recupero attivo [W]	4890	7270	10580
EER globale [W/W]	4,17	3,91	3,88
Perdita di carico lato acqua [kPa]	2	12	16
Perdita di carico lato aria [Pa]	60	46	51

ITEMS

CODE	DESCRIPTION
ACC700001	HEAT RECOVERY UNIT WITH THERMODYNAMIC SYSTEM "AIR DYN SYSTEM" - 1000m ³ /h
ACC700002	HEAT RECOVERY UNIT WITH THERMODYNAMIC SYSTEM "AIR DYN SYSTEM" - 1500m ³ /h
ACC700003	HEAT RECOVERY UNIT WITH THERMODYNAMIC SYSTEM "AIR DYN SYSTEM" - 2300m ³ /h
ACC700004	REMOTE USER TERMINAL FOR "AIR DYN SYSTEM"
ACC700005	COMPACT FILTER ePM1 70% FOR "AIR DYN SYSTEM" - 1000m ³ /h
ACC700006	COMPACT FILTER ePM1 70% FOR "AIR DYN SYSTEM" - 1500m ³ /h
ACC700007	COMPACT FILTER ePM1 70% FOR "AIR DYN SYSTEM" - 2300m ³ /h